

**ELECTRIC RATE TARIFFS
VOLUME II**

[This Volume supersedes Volume I in its entirety]

LAKELAND ELECTRIC

**A DEPARTMENT OF
THE CITY OF LAKELAND, FLORIDA**

**Rate Tariffs as Filed with
The Florida Public Service Commission**

TABLE OF CONTENTS

	<u>SHEET</u>
Title Page	1.0
Table of Contents	2.0
General Description of Service Area/Territory Served	3.0 - 3.1
List of Communities Served	4.0
Miscellaneous	5.0 - 5.3
Index of Rate Schedules.....	6.0 - 6.1
Rate Schedules	7.0 - 9.5
Standard Forms	9.6 - 9.8.1
Contracts, Agreements	9.9 - 14.0

**GENERAL DESCRIPTION OF
SERVICE AREA**

Lakeland's municipal electric system serves an area of approximately 246 square miles, all within a 15-mile radius of Lakeland. The service area is generally rectangular, 20 miles long and 13 miles wide, with the longer dimension running north and south. The western boundary of the service area is approximately 6 miles from the center of the City of Lakeland. The southern boundary is approximately 8 miles from the center of the city.

The service territory is bounded by the Withlacoochee River Electric Cooperative at the Northwest corner and the City of Bartow at the Southeast corner. The remainder of our service territory is surrounded by area served by Tampa Electric Company.

(Continued on Sheet No. 3.1)

LIST OF COMMUNITIES SERVED

1. Eaton Park – All
2. Highland City – All
3. Polk City (Incorporated) – All
4. Kathleen – All
5. Medulla – All
6. Providence – All
7. Gibsonia – All
8. Galloway – All

MISCELLANEOUS
ELECTRIC SERVICE CHARGES

Deposits:

Residential electric service - credit based	\$150 OR up to estimated two months average billing
Commercial construction (per single-phase meter)	\$100.00
Commercial service cash, bond, or irrevocable letter of credit	One (1) times the average monthly billing

Additional deposits may be required at the discretion of Lakeland Electric but not to exceed two months' billing.

Electric meter test:

Each additional test, in excess of one, in a 12-month period	\$50.00
--	---------

Cut-On Service Fees:

Initial cut-on fee (Truck roll)	\$20.00
Initial cut-on fee (No truck roll)	\$10.00
Transferring cut-on fee (Truck roll)	\$20.00
Transferring cut-on fee (No truck roll)	\$10.00
Delinquent cut-on fee at the electric meter	\$20.00
Delinquent cut-on fee at the electric pole	\$100.00
Cut-Off fee (Truck roll)	\$20.00
Cut-Off fee (No truck roll)	\$10.00
Same day cut fee	\$20.00
Cut-on after regular business hours and Saturday	\$50.00
Energy Diversion - plus damages and hourly cost in excess of one hour	\$60.00
Saturday cut-on fee	\$50.00

Service Charges to be applied after February 28, 2013 for change from Smart Meter Service to meter without remote interrogation capability:

Change-out from meter with remote interrogation	\$70.00
Monthly meter read fee	\$20.00
Meter re-read at request of Customer: (Truck)	\$20.00
Meter re-read at request of Customer: (Ping)	\$10.00
Cut-on, cut-off with Remote Disconnect Meter	\$10.00

(Continued on Sheet No. 5.1)

(Continued from Sheet No. 5.0)

Summary Billing:

1. Summary Billing Set Up Administration Fee \$50.00

2. Service Charge for Unpaid Checks and Collection Fees:
(for each returned check and collection of unpaid bills)

<u>Check Amt.</u>	<u>Fee</u>
\$0 - \$50.00	\$25.00
\$50.01 - \$300.00	\$30.00
\$300.01 - \$800.00	\$40.00
Above \$800.00	5% of total charges

Delinquent Charge:

Applied to customer's bill upon delinquency and due 30 days after the billing date - \$3.50 or 1.5% (percent) of the face value (whichever is greater)

Pay-As-You-Go Program Initial Set Up Administrative Fee \$50.00

Interest on Deposit:

Interest will be paid on customer accounts credited monthly at the same interest rate received by Lakeland Electric from the deposit of such funds. If deposit is terminated, the amount of interest is prorated and applied accordingly.

Metering Limitations:

1. Lakeland Electric will provide electric service to only one point and to only one meter on a structure when that structure serves only one entity, whether that entity be a person, a family, a business, an organization, or any other entity of any kind. Two or more persons residing in the same household shall not be considered as separate entities. A department, division, or wholly owned subsidiary or any other subdivision of a business or organization shall not be considered a separate entity.
2. When a structure serves more than one entity, Lakeland Electric will provide electric service to one point and to one meter for each entity served by that structure.
3. Any single entity having service through two or more meters on a structure prior to adoption of this policy shall be "grandfathered in." However, in the event any such structure is rebuilt and/or rewired, the provisions of paragraphs 1 and 2 above shall apply.

Provisions for Energy Pulse Data:

Lakeland Electric will provide energy pulses transmitted from its metering equipment to provide data to energy management systems. Time pulses will not be furnished.

(Continued on Sheet No. 5.2)

(Continued from Sheet No. 5.1)

All access to Lakeland Electric metering equipment shall be for its personnel. The pulses will normally be provided from a separate junction box which will be for Lakeland Electric access only.

Where the installation requires output of more than one pulse source, it shall be the responsibility of the customer to provide any required totalization of pulse data for customer's use.

Any replacement of material or equipment used solely to supply pulses to the customer shall be made by Lakeland Electric at the customer's expense.

All billing of demand and/or energy will be based upon Lakeland Electric's meter readings and not upon pulse data supplied. Lakeland Electric will not guarantee a certain pulse rate and the customer will be responsible for installing equipment necessary to change the pulse rate.

Data pulses will be provided through "dry" contacts only and will be limited to a customer imposed maximum of 1 ampere, 500-volt, 100-volt/ampere fused energy source.

The customer will contribute the full cost for the additional equipment required to provide the data pulse, the fee for which will be a minimum of \$400. Customer shall also provide equipment maintenance as required. All service charges will be calculated at cost by Lakeland Electric.

Installation Contract:

An agreement or contract must be executed, and the customer must make satisfactory arrangements for payment before installation can begin.

Continuity of Service:

Lakeland Electric will use reasonable diligence at all times to provide continuous service at the agreed nominal voltage and shall not be liable to the customer for complete or partial failure or interruption of service, or for fluctuations in voltage, resulting from causes beyond its control or through the ordinary negligence of its employees, servants or agents.

Lakeland Electric will use reasonable diligence in furnishing as uniform a supply of electric energy as practicable, except where rate schedules provide otherwise. Lakeland Electric may interrupt its service hereunder, however, for the purpose of making necessary alterations and repairs, but only for such time as may be reasonable or unavoidable, and shall, except in case of emergency, endeavor to minimize interruption.

(Continued from Sheet No. 5.2)

Whenever Lakeland Electric deems an emergency warrants interruption or limitation in the service being rendered, such interruption or limitation shall not constitute a breach of contract and shall not render Lakeland Electric liable for damages suffered thereby or excuse the customer further fulfillment of the contract.

Lakeland Electric shall not be liable to the customer for any loss, injury, or damage resulting from use of the customer's equipment or from the use of electric service furnished or from the connection of Lakeland Electric's facilities with the customer's wiring and appliances.

Electric Line Extensions:

Upon acceptance of the application for service, Lakeland Electric will proceed to do such work and to provide and install such equipment as may be necessary in order to render service. This may include the extension of an existing line when necessary. In general, where the major portion of an anticipated extension will be built on public rights-of-way and the new customer can reasonably be characterized as permanent, then Lakeland Electric will do all necessary construction at no cost to the customer. Where these guidelines clearly do not apply, Lakeland Electric may charge the customer all costs in excess of three times the estimated non-fuel revenue, (exclusive of the cost for transformers, secondary connections, and meters), and/or such other charges as the particular circumstance(s) may dictate. At the end of the initial three-year period, the actual total non-fuel revenues recovered will be compared with the estimated total non-fuel revenues and the customer shall be credited or debited accordingly. When kW demand factors, intermittent usage patterns, or premature investment result in necessarily inefficient utilization of Lakeland Electric facilities, Lakeland Electric may require cash advances or other means of providing a fair return on investment.

INDEX OF RATE SCHEDULES

	<u>Sheet No.</u>
Miscellaneous	5.0 - 5.0.3
Index of Rate Schedules.....	6.0 - 6.0.1
Residential Service (RS).....	7.0 - 7.0.1
Residential Service Shift to Save Optional Time-of-Day (RSX-1).....	7.1 - 7.1.1
Residential Service Demand- Residential Peak Demand (RSD).....	7.2 - 7.2.1
General Service and Construction Power (GS)	7.3 - 7.3.1
General Service Shift to Save Optional Time-of-Day (GSX-1).....	7.4 - 7.4.1
General Service Demand (GSD).....	7.5 - 7.5.1
General Service Demand Shift to Save Optional Time-of-Day (GSX-2).....	7.6 - 7.6.1
General Service Business Demand (GSBD).....	7.7 - 7.7.1
General Service Large Demand (GSLD).....	7.8 - 7.8.2
General Service Large Demand Shift to Save Optional Time-of-Day (GSX-3)	7.9 - 7.9.3
General Service Interruptible Rate (IS)	8.0 - 8.0.3
General Service Interruptible Rate Shift to Save Optional Time-of-Day(ISX-1)	8.1 - 8.1.3
Extra Large Demand Customer (ELDC)	8.2-8.2.1
Extra Large Demand Customer Shift to Save Optional Time-of-Day(ELDCX-1)	8.3-8.3.1
Net Metering Service (NM).....	8.4-8.4.2
Net Metering Service Interconnection Requirements for Photovoltaic Systems	8.5-8.5.1
Net Metering Service Application, Compliance Form, and Agreements	8.6-8.6.13

(Continued on Sheet No. 6.0.1)

(Continued from Sheet No. 6.0)

	<u>Sheet No.</u>
Firm Supplemental and Standby (SS-1)	8.7 - 8.7.3
Economic Development Rider (EDIR-1).....	8.8 - 8.8.1
Economic Development Rider (EDIR-2).....	8.9 - 8.9.1
Private Area Lighting (OL).....	9.0 - 9.0.3
Street and Roadway Lighting (OL-1)	9.1 - 9.1.3
Fuel Charge (BA-1)	9.2 - 9.2.1
Tax and Surcharge Adjustment (BA-2)	9.3
Environmental Compliance Cost Charge (BA-3).....	9.4
Smart Grid Project Implementation (BA-5)	9.5
Medically Essential Service	9.6
Bill Form.....	9.7 - 9.7.1
Bill Form with Past Due Notice.....	9.8 - 9.8.1
Interruptible Electric Service Agreement for GSLD Customers	9.9
Contract for Residential and Small Commercial Outdoor Lighting	10.0 – 10.1
Facilities Charge Agreement.....	11.0 - 11.0.2
Customer Participation in Renewable Energy Program	12.0 - 12.0.2
Surge Protection Program Meter Socket Surge Arrestor Lease Agreement.....	13.0
Service Agreement for Economic Development Rider	14.0

**RATE SCHEDULE - RS
RESIDENTIAL SERVICE**

Available:

In all territory served by Lakeland Electric.

Applicable:

To all electric service provided to single family homes, mobile homes, apartments, condominiums, or cooperative apartment buildings where such energy usage is exclusively for residential purposes subject to the following requirements:

1. 100% of the energy used is exclusively for the customer's benefit.
2. None of the energy is used in any endeavor which sells or rents a commodity or provides service for a fee.
3. Each point of delivery will be separately metered and billed.
4. A responsible legal entity is established as the customer to whom a bill can be rendered.
5. Beginning January 1, 2016, new solar electric systems interconnected with Lakeland Electric shall take service under Rate Schedule Residential Service Demand (RSD). Existing customers as of this date may maintain service under this rate scheduled through December 31, 2025.

Character of Service:

A-C; 60 Hertz; single-phase, 3-wire; 120/240 volts or 120/208 volts.

Limitation of Service:

Standby service or resale not permitted under this rate schedule.

Net Rate per Month:

Customer Charge:		\$14.45
Energy Charge:	0 to 1,000 kWh	\$0.0556185 per kWh
	1,001 to 1,500 kWh	\$0.0635492 per kWh
	Above 1,500 kWh	\$0.0703055 per kWh

Minimum Bill:

Customer charge, plus Adjustments.

(Continued on Sheet No. 7.0.1)

(Continued from Sheet No. 7.0)

Adjustments:

Fuel charge, as contained in Schedule BA-1
City Utility Tax or Surcharge, taxes, surcharges, and fees as contained in Schedule
BA-2
Environmental Compliance Cost Charge as contained in Schedule BA-3
Smart Grid Project Implementation as contained in Schedule BA-5

Payment:

Net bills are due when rendered and are delinquent thirty (30) days after the billing date.

Terms and Conditions:

1. All service hereunder will be supplied at one location through one point of delivery and measured through one meter.
2. Service hereunder is subject to the rules and regulations for electric service as adopted by Lakeland Electric from time to time and on file with the City Clerk.

**RATE SCHEDULE RSX-1
RESIDENTIAL SERVICE
SHIFT TO SAVE
OPTIONAL TIME-OF-DAY**

Available:

In all territory served by Lakeland Electric.

Applicable:

To all electric services provided to single family homes, mobile homes, apartments, condominiums, or cooperative apartment buildings where such energy usage is exclusively for residential purposes subject to the following requirements.

1. 100% of the energy used is exclusively for the customers' benefit.
2. None of the energy is used in any endeavor which sells or rents a commodity or provides a service for a fee.
3. Each point of delivery will be separately metered and billed.
4. A responsible legal entity is established as the customer to whom a bill can be rendered.
5. After January 1, 2016, service is no longer available for a customer with a solar electric system interconnected with Lakeland Electric. Service shall be moved to Rate Schedule Residential Service Demand (RSD).

Character of Service:

A-C; 60 Hertz; single-phase 3-wire; 120/240 volts or 120/208 volts.

Limitation of Service:

Resale not permitted under this rate schedule.

Net Rate per Month:

Customer Charge:	\$14.45
Energy Charge:	
On-Peak:	\$0.14140 per kWh
Off-Peak:	\$0.01592 per kWh

(Continued on Sheet No. 7.1.1)

(Continued from Sheet No. 7.1)

Definitions of the Time-of-Day Periods:
All time periods are stated in prevailing time.

	<u>Summer</u>	<u>Winter</u>
On-Peak Hours (Monday-Friday)	Apr. 1 - Oct. 31 12:01 PM - 9:00 PM	Nov. 1 - March 31 6:01 AM 10:00 AM, and, 6:01 PM - 10:00 PM

Off-Peak Hours: All other weekday hours, and all hours on Saturdays, Sundays, New Year's Day, Memorial Day, Independence Day, Labor Day, Thanksgiving Day, and Christmas Day shall be off-peak.

Minimum Bill:

Customer Charge, plus Adjustments.

Adjustments:

Fuel charge, as contained in Schedule BA-1
City Utility Tax or Surcharge, taxes, surcharges, and fees as contained in Schedule BA-2
Environmental Compliance Cost Charge as contained in Schedule BA-3
Smart Grid Project Implementation as contained in Schedule BA-5

Payment:

Net bills are due when rendered and are delinquent thirty (30) days after the billing date.

Terms and Conditions:

1. All service hereunder will be supplied at one location through one point of delivery and measured through one meter.
2. Service hereunder is subject to the rules and regulations for electric service as adopted by Lakeland Electric from time to time and on file with the City Clerk.
3. Customers who select to take service hereunder and subsequently terminate service shall be prohibited from returning to service hereunder for twelve (12) months unless approved by Lakeland Electric.

**RATE SCHEDULE RSD
RESIDENTIAL SERVICE DEMAND
RESIDENTIAL PEAK DEMAND**

Available: In all territory served by Lakeland Electric

Applicable:

To all electric services provided to single family homes, mobile homes, apartments, condominiums, or cooperative apartment buildings where such energy usage is exclusively for residential purposes subject to the following requirements:

- 1) Residential customer with solar electric systems interconnected with Lakeland Electric shall take service under this rate schedule either:
 - a) Beginning January 1, 2016, for new customers and existing customers under Rate Schedule Residential Service Shift to Save Optional Time-of-Day (RSX-1), or,
 - b) January 1, 2026, for customers who were on Rate Schedule Residential Service (RS) before January 1, 2016.
- 2) Residential customer with solar electric systems interconnected with Lakeland Electric shall receive a Value of Solar Credit beginning October 1, 2018.
Otherwise, service hereunder is available at the customer's option.
- 3) One-hundred percent (100%) of the energy used is exclusively for the customer's benefit.
- 4) None of the energy is used in any endeavor which sells or rents a commodity or provides service for a fee.
- 5) Each point of delivery will be separately metered and billed.
- 6) A responsible legal entity is established as the customer to whom a bill can be rendered.

Character of Service: A-C; 60 Hertz; single-phase 3-wire, 120/240 volts or 120/208 volts.

Limitation of Service: Standby service or resale not permitted under this rate schedule.

(Continued to Sheet No. 7.2.1)

(Continued from Sheet No. 7.2)

Net Rate Per Month:

Customer Charge: \$14.45
Demand Charge: \$6.69 per kW of Billing Demand
Value of Solar Credit: \$0.92 per kW of Billing Demand
Energy Charge: \$0.02674 per kWh

Definition of the Time-of-Day On-Peak Period:

All time periods are stated in prevailing time.

	<u>Summer</u>	<u>Winter</u>
On-Peak Hours	Apr. 1 - Oct. 31	Nov. 1 - March 31
(Monday-Friday)	1:01 PM - 8:00 PM	6:01 AM - 10:00 AM

Off-Peak Hours All other weekday hours, and all hours on Saturdays, Sundays, New Year's Day, Memorial Day, Independence Day, Labor Day, Thanksgiving Day, and Christmas Day shall be off-peak.

Minimum Bill:

Customer charge, plus Adjustments.

Adjustments:

Fuel charge, as contained in Schedule BA-1
City Utility Tax or Surcharge, taxes, surcharges, and fees as contained in Schedule BA-2
Environmental Compliance Cost Charge as contained in Schedule BA-3
Smart Grid Project Implementation as contained in Schedule BA-5

Payment:

Net bills are due when rendered and are delinquent thirty (30) days after the billing date.

Determination of Billing Demand:

The billing demand for the month shall be the maximum 30-minute integrated kilowatt on-peak demand in the month.

(Continued to Sheet No. 7.2.2)

(Continued from Sheet No. 7.2.1)

Where charges specified in a rate schedule are based upon the measured maximum 30-minute integrated demand, it is intended that such demand shall fairly represent the capacity which Lakeland Electric is required to stand ready to supply. In case of installations which use this service in a manner such that measurement over a 30-minute interval does not result in a fair or equitable measure of the supply capacity required to service the customer's load, then the measured demand may be adjusted taking into account the known character of use and the rating data of the equipment connected, or from special tests, the intent being that the demand so determined shall fairly represent the customer's capacity requirement.

In cases where Lakeland Electric elects to use connected load instead of demand measurement, as the method for determining demand, it will take into account the known character of use and the rating data of the equipment connected, the intent being that the demand so determined shall fairly represent the customer's capacity requirement.

Terms and Conditions:

1. All service hereunder will be supplied at one location through one point of delivery and measured through one meter.
2. Service hereunder is subject to the rules and regulations for electric service as adopted by Lakeland Electric from time to time and on file with the City Clerk.

**RATE SCHEDULE GS
GENERAL SERVICE AND CONSTRUCTION**

Available:

In all territory served by Lakeland Electric.

Applicable:

1. To any general service customer whose metered demand does not exceed 49 kW for more than two out of the twelve (12) most recent monthly billing periods, including the current billing period.
2. For Temporary Construction Power.
3. After January 1, 2016, a new solar electric system interconnected with Lakeland Electric shall take service under Rate Schedule General Service Business Demand (GSBD). Existing customers as of this date may maintain service under this rate schedule through December 31, 2025.

Character of Service:

A-C; 60 Hertz; single- or three-phase; 120/240 volts, 120/208 volts or any other voltage offered by Lakeland Electric.

Limitation of Service:

Not available for breakdown, standby, supplementary or resale service.

Connect and Disconnect Charge:

The connect and disconnect charge for Temporary Construction Power shall be \$125 per location payable with deposit at the time of application.

Net Rate per Month:

Customer Charge:	\$16.50
Energy Charge:	\$0.055144 per kWh

Minimum Bill:

Customer charge, plus Adjustments.

(Continued to Sheet No. 7.3.1)

(Continued from Sheet No. 7.3)

Adjustments:

- Fuel charge, as contained in Schedule BA-1
- City Utility Tax or Surcharge, taxes, surcharges, and fees as contained in Schedule BA-2
- Environmental Compliance Cost Charge as contained in Schedule BA-3
- Smart Grid Project Implementation as contained in Schedule BA-5

Payment:

Net bills are due when rendered and are delinquent thirty (30) days after the billing date.

Sports or Athletic Fields:

Sports or athletic fields which are operated by governmental or non-profit organizations, and which have measured demand of 50 kW or more (connected loads of 50 kW or more if connected load is used in lieu of demand measurement) may elect to be served under this provision of Rate Schedule GS, and billed at the following charges instead of the otherwise applicable Rate Schedule GSD or GSLD charges:

Net Rate Per Month:

Customer Charge:	\$ 16.50
Energy Charge:	\$0.06494 per kWh

Limitation of Service:

1. This provision is applicable only to non-profit organizations and to governmental agencies operating sports or athletic fields utilizing high efficiency lighting methods approved by Lakeland Electric.
2. Any field not using high efficiency lights on the effective date of this rate schedule is included in this provision, provided however, that any replacement or change in the lights after the effective date of this rate schedule shall be to high efficiency lights pursuant to a plan theretofore filed with and approved by Lakeland Electric. Any such plan must provide for a complete change to high efficiency lights within five (5) years of the effective date of this rate schedule. To be eligible for service under this provision, the non-profit organization, or governmental agency, shall file a plan within sixty (60) days of the effective date of this provision (4/1/83), or on the date electrical service is first provided, whichever is later. Any organization or agency failing to file such plan, or not complying with the plan approved for that organization or agency, shall be ineligible for service under this provision and shall

(Continued to Sheet 7.3.2)

(Continued from Sheet 7.3.1)

immediately convert to the regular customer classification under the applicable rate schedule based upon that customer's demand on the electric system and shall be liable for any and all charges under the applicable rate schedule, thereafter, including demand charges.

Terms and Conditions:

1. All service hereunder will be supplied at one location through one point of delivery and measured through one meter.
2. Service hereunder is subject to the rules and regulations for electric service as adopted by Lakeland Electric from time to time and on file with the City Clerk. Where the use of energy is for irrigation purposes, the customer agrees to accept the conditions of this schedule for a period of not less than twelve (12) consecutive months.

**RATE SCHEDULE GSX-1
GENERAL SERVICE
SHIFT TO SAVE
OPTIONAL TIME-OF-DAY**

Available:

In all territory served by Lakeland Electric.

Applicable:

1. To any general service customer whose metered demand does not exceed 49 kW for more than two (2) out of twelve (12) most recent monthly billing periods, including the current billing period.
2. After January 1, 2016, service is no longer available for a general service customer with a solar electric system interconnected with Lakeland Electric. Service shall be moved to Rate Schedule General Service Business Demand (GSBD).

Character of Service:

A-C; 60 Hertz; single or three phase; 120/240 volts, 120/208 volts, or any other voltage offered by Lakeland Electric.

Limitation of Service:

Resale not permitted under this rate schedule.

Net Rate Per Month:

Customer Charge:	\$16.50	
Energy Charge:		
On-Peak:	\$0.13901	per kWh
Off-Peak:	\$0.01710	per kWh

Definitions of the Time-of-Day Periods:

All time periods are stated in prevailing time.

(Continued to Sheet No. 7.4.1)

(Continued from Sheet No. 7.4)

	<u>Summer</u>	<u>Winter</u>
On-Peak Hours (Monday-Friday)	Apr. 1 - Oct. 31 12:01 PM - 9:00 PM	Nov. 1 - March 31 6:01 AM - 10:00 AM, and 6:01 PM - 10:00 PM
Off-Peak Hours	All other weekday hours, and all hours on Saturdays, Sundays, New Year's Day, Memorial Day, Independence Day, Labor Day, Thanksgiving Day, and Christmas Day shall be off-peak.	

Minimum Bill:

Customer charge, plus adjustments.

Adjustments:

Fuel charge, as contained in Schedule BA-1
City Utility Tax or Surcharge, taxes, surcharges, and fees as contained in Schedule BA-2
Environmental Compliance Cost Charge as contained in Schedule BA-3
Smart Grid Project Implementation as contained in Schedule BA-5

Payment:

Net bills are due when rendered and are delinquent thirty (30) days after the billing date.

Terms and Conditions:

1. All service hereunder will be supplied at one location through one point of delivery and measured through one meter.
2. Service hereunder is subject to the rules and regulations for electric service as adopted by Lakeland Electric from time to time and on file with the City Clerk.
3. Customers who elect to take service hereunder and subsequently terminate service shall be prohibited from returning to service hereunder for twelve (12) months unless approved by Lakeland Electric.

**RATE SCHEDULE GSD
GENERAL SERVICE DEMAND**

Available:

In all territory served by Lakeland Electric.

Applicable:

1. To any general service customer whose highest measured 30-minute interval demand has equaled or exceeded 50 kW three (3) or more months and has been less than 500 kW for ten (10) or more months of the twelve (12) most recent monthly billing periods, including the current billing period, or,
2. For Temporary Construction Power where the measured demand or connected load equals or exceeds 50 kW.

Character of Service:

A-C; 60 Hertz; single- or three-phase, at any standard utility voltage level offered by Lakeland Electric.

Limitation of Service:

Not available for breakdown, standby, supplementary or resale service.

Connect and Disconnect Charge:

The connect and disconnect charge for Temporary Construction Power shall be based on any special facilities that the utility has to furnish and install.

Net Rate per Month:

Customer Charge: \$58.25
Demand Charge: \$9.52 per kW of Billing Demand
Energy Charge: \$0.02110 per kWh

Minimum Bill:

Customer charge, facilities charge, plus Adjustments.

(Continued to Sheet No. 7.5.1)

(Continued from Sheet No. 7.5)

Adjustments:

- Fuel charge, as contained in Schedule BA-1
- City Utility Tax or Surcharge, taxes, surcharges, and fees as contained in Schedule BA-2
- Environmental Compliance Cost Charge as contained in Schedule BA-3
- Smart Grid Project Implementation as contained in Schedule BA-5

Payment:

Net bills are due when rendered and are delinquent thirty (30) days after the billing date.

Determination of Billing Demand:

The billing demand for the month shall be the maximum 30-minute integrated kilowatt demand in the month.

Where charges specified in a rate schedule are based upon the measured maximum 30-minute integrated demand, it is intended that such demand shall fairly represent the capacity which Lakeland Electric is required to stand ready to supply. In case of installations which use this service in a manner such that measurement over a 30-minute interval does not result in a fair or equitable measure of the supply capacity required to service the customer's load, then the measured demand may be adjusted taking into account the known character of use and the rating data of the equipment connected, or from special tests, the intent being that the demand so determined shall fairly represent the customer's capacity requirement.

In cases where Lakeland Electric elects to use connected load instead of demand measurement, as the method for determining demand, it will take into account the known character of use and the rating data of the equipment connected, the intent being that the demand so determined shall fairly represent the customer's capacity requirement.

Primary Voltage Service:

Service at primary voltage, where available, will be supplied under this rate schedule upon request. When service is supplied at the primary voltage the customer will own and maintain all substations, lines, transformer supporting structures, transformers and other equipment required for utilization of the delivery voltage. Lakeland Electric will own no equipment beyond the primary voltage metering point. A **twenty-six cent (\$0.26)** discount on demand charge and a 4.8 percent (4.8%) discount on energy, plus non-exempt fuel as specified in Schedule BA-2 charges and on the Schedule BA-3 charge, will be allowed when service is delivered and metered at primary voltage.

(Continued to Sheet 7.5.2)

(Continued from Sheet 7.5.1)

Secondary Service Metered at Primary Voltage:

In cases where secondary service is being supplied and Lakeland Electric has elected to meter the service at primary voltage, there will be a discount of **twenty-six cents (\$0.26)** applied to the demand charge and one-percent (1%) applied to energy, plus non-exempt fuel as specified in Schedule BA-2, charges and to the Schedule BA-3 charge. No new secondary service will be constructed with metering at the primary voltage.

Facilities Charge:

When the customer requires the utility to furnish and install special facilities for the exclusive use of the customer, such customer will be required to pay a facilities charge in addition to the above demand and energy rate. The facilities charge will be based upon the cost of such excess facilities.

Terms and Conditions:

1. All service hereunder will be supplied at one location through one point of delivery and measured through one meter.
2. Service hereunder is subject to the rules and regulations for electric service as adopted by Lakeland Electric from time to time and on file with the City Clerk.
3. Where the use of energy is for irrigation purposes, the customer agrees to accept the conditions of this schedule for a period of not less than twelve (12) consecutive months.

**RATE SCHEDULE GSX-2
GENERAL SERVICE DEMAND
SHIFT TO SAVE
OPTIONAL TIME-OF-DAY**

Available:

In all territory served by Lakeland Electric.

Applicable:

To any general service customer whose highest measured 30-minute interval demand has equaled or exceeded 50 kW for three (3) or more months and has been less than 500 kW for ten (10) or more months of the twelve (12) most recent monthly billing periods, including the current billing period.

Character of Service:

A-C; 60 Hertz; single or three phase; at any standard utility voltage level offered by Lakeland Electric.

Limitation of Service:

1. Resale not permitted under this rate schedule.
2. General Service Customers with interconnected solar electric systems shall take service under Rate Schedule GSD.

Net Rate per Month:

Customer Charge:	\$58.25
Demand Charge:	\$9.52 per kW of Billing Demand
Energy Charge:	
On-Peak:	\$0.05049 per kWh
Off-Peak:	\$0.00593 per kWh

Definitions of the Time-of-Day Periods:

All time periods are stated in prevailing time.

	<u>Summer</u>	<u>Winter</u>
On-Peak Hours	<u>Apr. 1 - Oct. 31</u>	<u>Nov. 1 - March 31</u>
(Monday - Friday)	12:01 PM - 9:00 PM	6:01 AM - 10:00 AM, and 6:01 PM - 10:00 PM

(Continued to Sheet No. 7.6.1)

Issued by: Cynthia Clemmons
Manager of Legislative & Regulatory Relations

Effective Date: October 1, 2025

(Continued from Sheet No. 7.6)

Definitions of the Time-of-Day Periods: (Continued)

Off-Peak Hours: All other weekday hours, and all hours on Saturdays, Sundays, New Year's Day, Memorial Day, Independence Day, Labor Day, Thanksgiving Day, and Christmas Day shall be off-peak.

Minimum Bill:

Customer charge, Facilities Charge, plus Adjustments.

Adjustments:

Fuel charge, as contained in Schedule BA-1
City Utility Tax or Surcharge, taxes, surcharges, and fees as contained in Schedule BA-2
Environmental Compliance Cost Charge as contained in Schedule BA-3
Smart Grid Project Implementation as contained in Schedule BA-5

Payment:

Net bills are due when rendered and are delinquent thirty (30) days after the billing date.

Determination of Billing Demand:

Billing demand is the maximum 30-minute interval demand established during the current on-peak period.

Where charges specified in a rate schedule are based upon the measured maximum 30-minute integrated demand, it is intended that such demand shall fairly represent the capacity which Lakeland Electric is required to stand ready to supply.

In case of installations which use this service in a manner such that measurement over a 30-minute interval does not result in a fair or equitable measure of the supply capacity required to serve the customer's load, then the measured demand may be adjusted taking into account the known character of use and the rating data of the equipment connected, or from special tests, the intent being that the demand so determined shall fairly represent the customer's capacity requirement.

(Continued to Sheet No. 7.6.2)

(Continued from Sheet No. 7.6.1)

In cases where Lakeland Electric elects to use connected load, instead of demand measurement, as the method for determining demand, it will take into account the known character of use and the rating data of the equipment connected, the intent being that the demand so determined shall fairly represent the customer's capacity requirement.

Primary Voltage Service:

Service at primary voltage, where available, will be supplied under this rate schedule upon request. When service is supplied at primary voltage the customer will own and maintain all substations, lines, transformer supporting structures, transformers and other equipment required for utilization of the delivery voltage. Lakeland Electric will own no equipment beyond the primary voltage metering point. A twenty-six cent (\$0.26) discount on demand charge and a 4.8 percent (4.8%) discount on energy, plus taxable fuel as specified in Schedule BA-2, charges and on the Schedule BA-3 charge, will be allowed when service is delivered and metered at primary voltage.

Secondary Service Metered at Primary Voltage:

In cases where secondary service is being supplied and Lakeland Electric has elected to meter the service at primary voltage, there will be discounts of twenty-six cents (\$0.26) applied to demand and one-percent (1%) applied to energy, plus taxable fuel as specified in Schedule BA-2, charges and to the Schedule BA-3 charge. No new secondary service will be constructed with metering at the primary voltage.

Facilities Charge:

When the customer requires the utility to furnish and install special facilities for the exclusive use of the customer, such customer will be required to pay a facilities charge in addition to the above demand and energy rate. The facilities charge will be based upon the cost of such excess facilities.

Terms and Conditions:

1. All service hereunder will be supplied at one location through one point of delivery and measured through one meter.
2. Service hereunder is subject to the rules and regulations for electric service as adopted by Lakeland Electric from time to time and on file with the City Clerk.
3. Customers who elect to take service hereunder and subsequently terminate service shall be prohibited from returning to service hereunder for twelve (12) months unless approved by Lakeland Electric.

Issued by: Cynthia Clemmons
Manager of Legislative & Regulatory Relations

Effective Date: October 1, 2025

**RATE SCHEDULE - GSBD
GENERAL SERVICE BUSINESS DEMAND**

Available:

In all territory served by Lakeland Electric.

Applicable:

1. To any general service customer whose metered demand does not exceed 49 kW, for more than two (2) out of the twelve (12) most recent monthly billing periods, including the current billing period, or,
2. For Temporary Construction Power, or,
3. General Service customers with solar electric systems interconnected with Lakeland Electric, beginning January 1, 2016, for new general service customers and after December 31, 2025, for existing general service customers, and not exceeding 49 kW as described above shall take service under this schedule. Otherwise, this rate schedule is an option to the otherwise applicable general service rate schedules.

Character of Service:

A-C; 60 Hertz; single- or three-phase; 120/240 volts, 120/208 volts or any other voltage offered by Lakeland Electric.

Limitation of Service:

Not available for breakdown, standby, supplementary or resale service.

Connect and Disconnect Charge:

The connect and disconnect charge for Temporary Construction Power Shall be \$125 per location payable with deposit at the time of application.

Net Rate per Month:

Customer Charge:	\$16.50
Demand Charge:	\$6.81 per kW of Billing Demand
Energy Charge:	\$0.0257462 per kWh

(Continued to Sheet No. 7.7.1)

(Continued from Sheet No. 7.7)

Minimum Bill:

Customer Charge, plus Adjustments.

Adjustments:

Fuel charge, as contained in Schedule BA-1
City Utility Tax or Surcharge, taxes, surcharges, and fees as contained in Schedule BA-2
Environmental Compliance Cost Charge as contained in Schedule BA-3
Smart Grid Project Implementation as contained in Schedule BA-5

Payment:

Net bills are due when rendered and are delinquent thirty (30) days after the billing date.

Determination of Billing Demand:

The billing demand for the month shall be the maximum 30-minute integrated kilowatt demand in the month.

Where charges specified in a rate schedule are based upon the measured maximum 30-minute integrated demand, it is intended that such demand shall fairly represent the capacity which Lakeland Electric is required to stand ready to supply. In case of installations which use this service in a manner such that measurement over a 30-minute interval does not result in a fair or equitable measure of the supply capacity required to serve the customer's load, then the measured demand may be adjusted taking into account the known character of use and the rating data of the equipment connected, or from special tests, the intent being that the demand so determined shall fairly represent the customer's capacity requirement.

In cases where Lakeland Electric elects to use connected load, instead of demand measurement, as the method for determining demand, it will take into account the known character of use and the rating data of the equipment connected, the intent being that the demand so determined shall fairly represent the customer's capacity requirement.

Terms and Conditions:

1. All service hereunder will be supplied at one location through one point of delivery and measured through one meter.

(Continued to Sheet No. 7.7.2)

(Continued from Sheet No. 7.7.1)

2. Service hereunder is subject to the rules and regulations for electric service as adopted by Lakeland Electric from time to time and on file with the City Clerk.
3. Where the use of energy is for irrigation purposes, the customer agrees to accept the condition of this schedule for a period of not less than twelve (12) consecutive months.

**RATE SCHEDULE - GSLD
GENERAL SERVICE LARGE DEMAND**

Available:

In all territory served by Lakeland Electric.

Applicable:

To any general service customer whose highest 30-minute interval demand exceeds 499 kW for three or more of the twelve (12) most recent monthly billing periods, including the current billing period.

1. General Service Large Demand Customers with interconnected solar electric systems shall take service under Rate Schedule General Service Large Demand (GSLD).

Character of Service:

A-C; 60 Hertz; three-phase; at any standard utility voltage level offered by Lakeland Electric.

Limitation of Service:

Not available for breakdown, standby, supplementary or resale service.

Net Rate per Month:

Customer Charge:	\$557.00
Demand Charge:	\$11.16 per kW of Billing Demand
Energy Charge:	\$0.016349 per kWh

Minimum Bill:

Customer Charge, Facilities Charge, plus Adjustments.

Adjustments:

Fuel Charge, as contained in Schedule BA-1
City Utility Tax or Surcharge, taxes, surcharges, and fees as contained in Schedule BA-2
Environmental Compliance Cost Charge as contained in Schedule BA-3
Smart Grid Project Implementation as contained in Schedule BA-5

(Continued to Sheet No. 7.8.1)

(Continued from Sheet No. 7.8)

Payment:

Net bills are due when rendered and delinquent thirty (30) days after the billing date.

Determination of Demand:

Where charges specified in a rate schedule are based upon the measured maximum 30-minute integrated demand, it is intended that such demand shall fairly represent the capacity which the Department is required to stand ready to supply.

In case of installations which use this service in a manner such that measurement over a 30-minute interval does not result in a fair or equitable measure of the supply capacity required to serve the customer's load, then the measured demand may be adjusted taking into account the known character of use and the rating data of the equipment connected, or from special tests, the intent being that the demand so determined shall fairly represent the customer's capacity requirement.

In cases where Lakeland Electric elects to use connected load, instead of demand measurement, as the method for determining demand, it will take into account the known character of use and the rating data of the equipment connected, the intent being that the demand so determined shall fairly represent the customer's capacity requirement.

Primary Voltage Service:

Service at primary voltage, where available, will be supplied under this rate schedule upon request. When service is supplied at primary voltage the customer will own and maintain all substations, lines, transformer supporting structures, transformers and other equipment required for utilization of the delivery voltage. Lakeland Electric will own no equipment beyond the primary voltage metering point. A twenty-six cent (\$0.26) discount on demand charges and a 4.8 percent (4.8%) discount on energy, plus taxable fuel as specified in Schedule BA-2 charges and on Schedule BA-3 charge will be allowed when service is delivered and metered at primary voltage.

Secondary Service Metered at Primary Voltage:

In cases where secondary service is being supplied, but Lakeland Electric has elected to meter the service at primary voltage, there, will be discounts of twenty-six cents (\$0.26) applied to the demand charge and one-percent (1%) applied to energy, plus taxable fuel as specified in Schedule BA-2 charges and to the Schedule BA-3 charge. No new secondary service will be constructed with the metering at the primary voltage.

(Continued to Sheet No. 7.8.2)

(Continued from Sheet No. 7.8.1)

Facilities Charge:

When the customer requires the utility to furnish and install special facilities for the exclusive use of the customer, such customer will be required to pay a facilities charge in addition to the above demand and energy rate. The facilities charge will be based upon the cost of such excess facilities.

Terms and Conditions:

1. All service hereunder will be supplied at one location through one point of delivery and measured through one meter.
2. The power factor at the time of the monthly peak demand must be maintained above 90 percent (90%).
3. Service hereunder is subject to the rules and regulations for electric service as adopted by Lakeland Electric from time to time and on file with the City Clerk.

**RATE SCHEDULE - GSX-3
GENERAL SERVICE LARGE DEMAND
SHIFT TO SAVE
OPTIONAL TIME-OF-DAY**

Available:

In all territory served by Lakeland Electric.

Applicable:

To any general service customer whose highest 30-minutes interval demand exceeds 499 kW in three (3) or more out of the twelve (12) most recent monthly billing periods including the current billing period.

Character of Service:

A-C; 60 Hertz; three-phase; at any standard utility voltage level offered by Lakeland Electric.

Limitation of Service:

1. Resale not permitted under this rate schedule.
2. General Service Large Demand Customers with interconnected solar electric systems shall take service under Rate Schedule General Service Large Demand (GSLD).

Net Rate per Month:

Customer Charge:	\$557.00
Demand Charge:	\$11.16 per kW of Billing Demand
Energy Charge:	
On-Peak:	\$0.0358334 per kWh
Off-Peak:	\$0.0068801 per kWh

(Continued to Sheet No. 7.9.1)

(Continued from Sheet No. 7.9)

Definitions of the Time-of-Day Periods:

All time periods are stated in prevailing time.

	<u>Summer</u>	<u>Winter</u>
On-Peak Hours (Monday - Friday)	<u>Apr. 1 - Oct. 31</u> 12:01 PM - 9:00 PM	<u>Nov. 1 - March 31</u> 6:01 AM - 10:00 AM, and 6:01 PM - 10:00 PM

Off-Peak Hours All other weekday hours, and all hours on Saturdays, Sundays, New Year's Day, Memorial Day, Independence Day, Labor Day, Thanksgiving Day, and Christmas Day shall be off-peak.

Minimum Bill:

Customer Charge, Facilities Charge, plus Adjustments.

Payment:

Net bills are due when rendered and are delinquent thirty (30) days after the billing date.

Adjustments:

Fuel Charge, as contained in Schedule BA-1
City Utility Tax or Surcharge, taxes, surcharges, and fees as contained in Schedule BA-2
Environmental Compliance Cost Charge as contained in Schedule BA-3
Smart Grid Project Implementation as contained in Schedule BA-5

Determination of Billing Demand:

Billing demand is the maximum 30-minute interval demand established during the current on-peak period.

Where charges specified in a rate schedule are based upon the measured maximum 30-minute integrated demand, it is intended that such demand shall fairly represent the capacity which Lakeland Electric is required to stand ready to supply.

(Continued to Sheet No. 7.9.2)

(Continued from Sheet No. 7.9.1)

Determination of Billing Demand: (Continued)

In case of installations which use this service in a manner such that measurement over a 30-minute interval does not result in a fair or equitable measure of the supply capacity required to serve the customer's load, then the measured demand may be adjusted taking into account the known character of use and the rating data of the equipment connected or from special tests, the intent being that the demand so determined shall fairly represent the customer's capacity requirement.

In cases where Lakeland Electric elects to use connected load, instead of demand measurement, as the method for determining demand, it will take into account the known character of use and the rating data of the equipment connected, the intent being that the demand so determined shall fairly represent the customer's capacity requirement.

Primary Voltage Service:

Service at primary voltage, where available, will be supplied under this rate schedule upon request. When service is supplied at primary voltage the customer will own and maintain all substations, lines, transformer supporting structures, transformers and other equipment required for utilization of the delivery voltage. Lakeland Electric will own no equipment beyond the primary voltage metering point. A twenty-six cent (\$0.26) discount on demand charge and a 4.8 percent (4.8%) discount on energy charge, plus taxable fuel as specified in Schedule BA-2 charges, and a Schedule BA-3 charge will be allowed when service is delivered and metered at primary voltage.

Secondary Service Metered at Primary Voltage:

In cases where secondary service is being supplied, but Lakeland Electric has elected to meter the service at primary voltage, there, will be discounts of twenty-six cents (\$0.26) applied to the demand charge and 1 percent (1%) applied to energy, plus taxable fuel as specified in Schedule BA-2 charges and to the Schedule BA-3 charge. No new secondary service will be constructed with the metering at the primary voltage.

Facilities Charge:

When the customer requires the utility to furnish and install special facilities for the exclusive use of the customer, such customer will be required to pay a facilities charge in addition to the above demand and energy rate. The facilities charge will be based upon the cost of such excess facilities.

(Continued to Sheet No. 7.9.3)

(Continued from Sheet No. 7.9.2)

Terms and Conditions:

1. All service hereunder will be supplied at one location through one point of delivery and measured through one meter.
2. The power factor at the time of the monthly peak demand must be maintained above 90 percent (90%).
3. Service hereunder is subject to the rules and regulations for electric service as adopted by Lakeland Electric from time to time on file with the City Clerk.

RATE SCHEDULE - IS
GENERAL SERVICE INTERRUPTIBLE
(Closed to New Business as of February 1, 2015)

Available:

In all territory served by Lakeland Electric.

Applicable:

1. To any customer qualified by the conditions set forth in this schedule where the total metered demand is 1,000 kW or greater and where service may be interrupted by Lakeland Electric. Customer shall meet or exceed minimum demand three or more of the twelve (12) most recent monthly billing periods, including the current billing period.
2. Service under this rate schedule is not offered to customers for whom an interruption would interfere with functions necessary for the protection of public health and safety.
3. Closed to new business as of February 1, 2015.

Character of Service:

The electric energy delivered under this schedule shall be A-C; 60 Hertz; three-phase; at the standard utility voltage offered by Lakeland Electric.

Limitation of Service:

1. Resale not permitted under this rate schedule.
2. Service hereunder is at the sole option of Lakeland Electric, and may be interrupted if electric power and energy delivered hereunder is required to:
 - a. provide service to its firm power customers during periods of capacity shortages; or
 - b. supply emergency interchange to other utilities for their firm load obligations.
3. Lakeland Electric reserves the right to limit the total load served under this schedule.
4. Each point of delivery served hereunder shall have installed special equipment to insure immediate discontinuance of service in the event of a system disturbance. Such special equipment shall be under the sole control of Lakeland Electric.

Notice of Interruption:

In the event an interruption is called in response to Limitation of Service, Lakeland Electric will attempt to provide no less than 30 minutes' notice. Notice of less than 30 minutes may be given if necessary to prevent loss of power to firm service customers.

(Continued to Sheet No. 8.0.1)

(Continued from Sheet No. 8.0)

Net Rate Per Month:

Customer Charge:	\$557.00
Demand Charge:	\$11.16 per kW of Billing Demand
Controlled Demand Credit:	\$4.86 per kW of Controlled Demand
Energy Charge:	\$0.0163493 per kWh

Minimum Bill:

Customer Charge, Facilities Charge, plus Adjustments-

Adjustments:

Fuel Charge, as contained in Schedule BA-1
City Utility Tax or Surcharge, taxes, surcharges, and fees as contained in Schedule BA-2
Environmental Compliance Cost Charge as contained in Schedule BA-3

Payment:

Net bills are due when rendered and are delinquent thirty (30) days after the billing date.

Determination of Billing Demand:

The billing demand for the month shall be the maximum 30-minute integrated kilowatt demand in the month.

Where charges specified in a rate schedule are based upon the measured maximum 30-minute integrated demand, it is intended that such demand shall fairly represent the capacity which Lakeland Electric is required to stand ready to supply. In case of installations which use this service in a manner such that measurement over a 30-minute interval does not result in a fair or equitable measure of the supply capacity required to serve the customer's load, then the measured demand may be adjusted taking into account the known character of use and the rating data of the equipment connected, or from special tests, the intent being that the demand so determined shall fairly represent the customer's capacity requirement.

In cases where Lakeland Electric elects to use connected load, instead of demand measurement, as the method for determining demand, it will take into account the known character of use and the rating data of the equipment connected, the intent being that the demand so determined shall fairly represent the customer's capacity requirement.

(Continued to Sheet 8.0.2)

(Continued from Sheet No. 8.0.1)

Controlled Demand:

The amount recognized by Lakeland Electric as available for interruption.

Primary Voltage Service:

Service at primary voltage, where available, will be supplied under this rate schedule upon request. When service is supplied at primary voltage the customer will own and maintain all substations, lines, transformer supporting structures, transformers and other equipment required for utilization of the delivery voltage. Lakeland Electric will own no equipment beyond the primary voltage metering point.

A twenty-six cent (\$0.26) per KW metering voltage discount on demand charges and a 4.8 percent (4.8%) discount on energy, plus taxable fuel as specified in Schedule BA-2 charges and on Schedule BA-3 charges will be allowed when service is delivered and metered at primary voltage.

Secondary Service Metered at Primary Voltage:

In cases where secondary service is being supplied, but Lakeland Electric has elected to meter the service at primary voltage, there will be discounts of twenty-six cents (\$0.26) applied to the demand charge and one-percent (1%) applied to the demand and energy charges, plus taxable fuel as specified in Schedule BA-2 charges and to the Schedule BA-3 charge. No new secondary service will be constructed with metering at the primary voltage.

Facilities Charge:

When the customer requests and Lakeland Electric agrees to furnish, install, and maintain facilities for the exclusive use of the customer, such customer will be required to pay a facilities charge in addition to the above demand and energy rate. The facilities charge will be based upon the cost of such excess facilities.

Temporary Discontinuance on Service:

There will be no adjustments made for temporary discontinuance of service for seasonal or intermittent use of energy under this service schedule. Any customer prior to resuming service within twelve (12) months after discontinuance of service shall pay all charges which would have been billed had service been continued. Such bills shall be determined using zero (0) demand and energy meter readings for the period of service discontinuance.

(Continued to Sheet No. 8.0.3)

(Continued from Sheet No. 8.0.2)

Terms and Conditions:

1. Power factor at the time of the monthly peak demand must be maintained above 90 percent (90%).
2. Service hereunder is subject to the rules and regulations for electric service as adopted by Lakeland Electric - from time to time and on file with the City Clerk.
3. When the customer increases its electrical load, which increase requires Lakeland Electric to increase facilities installed for the specific use of the customer, a new Term of Service may be required under this rate at the option of Lakeland Electric.
4. Lakeland Electric may, under the provisions of this rate, at its option, require a special contract with the customer.
5. Lakeland Electric will furnish service under this rate at a single voltage through one point of delivery and measured through one meter. Equipment to supply additional voltages or additional facilities for the use of the customer shall be furnished and maintained by the customer.
6. Customers taking service under this interruptible rate schedule who desire to transfer to a non-interruptible rate schedule will be required to give Lakeland Electric written notice at least sixty (60) months prior to such transfer. Such notice shall be irrevocable unless Lakeland Electric and the customer shall mutually agree to void the revocation. Transferring to another interruptible rate schedule for which the customer is eligible is not subject to this notice provision.
7. So long as the customer remains eligible for service under this rate schedule Lakeland Electric shall not terminate service without sixty (60) months' written notice.
8. Customers requesting service under this interruptible rate schedule must have a minimum of 500 kW of demand that is available for interruption during the utility's peak or emergency conditions.
9. In the event the customer fails to deliver the specified interruptible load, billing adjustments will be made, back to the most recent interruption by Lakeland Electric, to remove the Controlled Demand Credit. The adjustment shall be billed at a rate 1.25 times the Controlled Demand Credit. The customer shall be ineligible for the Controlled Demand Credit until the ability to deliver the agreed interruptible load is demonstrated.
10. Lakeland Electric may, but is not required to, purchase power and energy from other sources for the customer's use during periods when interruptions are required but is not required to do so pursuant to this schedule. When possible, Lakeland Electric will provide advance notification of purchases made for the customer or as soon as practical thereafter and similar notification will be provided upon termination of such purchases.

(Continued to Sheet No. 8.0.4)

Terms and Conditions (Continued):

The customer will be required to pay the actual charges of such purchases in lieu of the otherwise applicable energy charges (energy charge, capacity charge, and fuel adjustment) provided in this rate schedule. These costs shall be based on the customer's proportionate share of a higher cost of such purchased energy plus 1.04 mills per kWh. The cost of such purchased energy shall be based on the average cost of all purchased power and energy provided under this rate schedule during the corresponding calendar month.

11. Lakeland Electric, when possible, will provide advance notification when interruptions are imminent or as soon as practical; thereafter, when advance notice is not feasible.

RATE SCHEDULE - ISX-1
GENERAL SERVICE INTERRUPTIBLE RATE
SHIFT TO SAVE
OPTIONAL TIME-OF-DAY

(Closed to New Business as of February 1, 2015)

Available:

In all territory served by Lakeland Electric but closed to new business as of February 1, 2015.

Applicable:

1. To any customer qualified by the conditions set forth in this schedule and otherwise eligible for service under Schedule IS where the total metered demand is 1,000 kW or greater and where service may be interrupted by Lakeland Electric.
2. Service under this rate schedule is not offered to customers for whom an interruption would interfere with functions necessary for the protection of public health and safety.

Character of Service:

The electric energy delivered under this schedule shall be A-C; 60 Hertz; three-phase; at the standard utility voltage offered by Lakeland Electric.

Limitation of Service:

1. Resale not permitted under this rate schedule.
2. Service hereunder is at the sole option of Lakeland Electric and available only after a twelve (12) month comparison of billing on this schedule and rate IS has been completed.
3. Lakeland Electric reserves the right to limit the total load served under this schedule.
4. Electric power and energy service supplied hereunder may be interrupted if required to:
 - a. Provide service to its firm power customers during periods of capacity shortages; or
 - b. Supply emergency interchange to other utilities for their firm load obligations.
5. Each point of delivery shall have installed equipment to insure immediate discontinuance of service in the event of a system disturbance. Such special equipment shall be under the sole control of Lakeland Electric.

Notice of Interruption:

When possible, Lakeland Electric will provide advanced notification when interruptions are imminent or as soon as practical, thereafter, when advance notice is not feasible.

(Continued to Sheet No. 8.1.1)

(Continued from Sheet No. 8.1)

Net Rate per Month:

Customer Charge: \$557.00
Demand Charge: \$11.16 per kW of Billing Demand
Controlled Demand Credit: \$4.86 per kW of Controlled Demand

Energy Charge:
On Peak: \$0.04126 per kWh
Off Peak: \$0.00751 per kWh

All time periods are stated in prevailing time.

	<u>Summer</u>	<u>Winter</u>
On-Peak Hours	<u>Apr. 1 - Oct. 31</u>	<u>Nov. 1 - March 31</u>
(Monday - Friday)	12:01 PM - 9:00 PM	6:01 AM -10:00 AM and 6:01 PM - 10:00 PM

Off-Peak Hours:
All other weekday hours, and all hours on Saturdays, Sundays, New Year's Day, Memorial Day, Independence Day, Labor Day, Thanksgiving Day, and Christmas Day shall be off-peak.

Minimum Bill:

Customer Charge, Facilities Charge, plus Adjustments.

Adjustments:

Fuel Charge, as contained in Schedule BA-1
City Utility Tax or Surcharge, taxes, surcharges, and fees as contained in Schedule BA-2
Environmental Compliance Cost Charge as contained in Schedule BA-3

Payment:

Net bills are due when rendered and are delinquent thirty (30) days after the billing date.

Determination of Billing Demand:

Billing demand is the maximum 30-minute interval demand established during the current one-peak period.

(Continued to Sheet No. 8.1.2)

(Continued from Sheet No. 8.1.1)

Where charges specified in a rate schedule are based upon the measured maximum 30-minute integrated demand, it is intended that such demand shall fairly represent the capacity which Lakeland Electric is required to stand ready to supply.

In case of installations which use this service in a manner such that measurement over a 30-minute interval does not result in a fair or equitable measure of the supply capacity required to serve the customer's load, then the measured demand may be adjusted taking into account the known character of use and the rating data of the equipment connected or from special tests, the intent being that the demand so determined shall fairly represent the customer's capacity requirement.

Determination of Billing Demand (Continued):

In cases where Lakeland Electric, at its sole discretion, elects to use connected load, instead of demand measurement, as the method for determining demand, it will take into account the known character of use and the rating data of the equipment connected, the intent being that the demand so determined shall fairly represent the customer's capacity requirement.

Controlled Demand:

The amount recognized by Lakeland Electric as available for interruption.

Delivery Voltage Discounts:

Primary Voltage Service:

Service at primary voltage, where available, will be supplied under this rate schedule upon request. When service is supplied at primary voltage the customer will own and maintain all substations, lines, transformer supporting structures, transformers and other equipment required for utilization of the delivery voltage. Lakeland Electric will own no equipment beyond the primary voltage metering point.

A twenty-six cent (\$0.26) per KW metering voltage discount on demand charges and a 4.8 percent (4.8%) discount on energy, plus non-exempt fuel as specified in Schedule BA-2 charges and on Schedule BA-3 (ECCC) charges will be allowed when service is delivered and metered at primary voltage.

(Continued to Sheet No. 8.1.3)

(Continued from Sheet No. 8.1.2)

Secondary Service Metered at Primary Voltage:

In cases where secondary service is being supplied, but Lakeland Electric has elected to meter the service at primary voltage, there will be discounts of **twenty-six cents** (\$0.26) applied to the demand charge and one-percent (1%) applied to energy and taxable fuel as specified in Schedule BA-2 charges and to the Schedule BA-3 charge. No new secondary service will be constructed with metering at the primary voltage.

Facilities Charge:

When the customer requests Lakeland Electric agrees to furnish, install, and maintain facilities for the exclusive use of the customer, such customer will be required to pay facilities charge in addition to the above demand and energy rate. The facilities charge will be based upon the cost of such excess facilities.

Temporary Discontinuance on Service:

There will be no adjustments made for temporary discontinuance of service for seasonal or intermittent use of energy under this service schedule. Any customer prior to resuming service within twelve (12) months after discontinuance of service shall pay all charges which would have been billed had service been continued. Such bills shall be determined using zero (0) demand and energy meter readings for the period of service discontinuance.

Terms and Conditions:

1. Power factor at the time of the monthly peak demand must be maintained above 90 percent (90%).
2. Service hereunder is subject to the rules and regulations for electric service as adopted by Lakeland Electric - from time to time and on file with the City Clerk.
3. When the customer increases his electrical load, which increase requires Lakeland Electric to increase facilities installed for the specific use of the customer, a new Term of Service may be required under this rate at the option of Lakeland Electric.
4. Lakeland Electric may, under the provisions of this rate, at its option, require a special contract with the customer.
- 5.

(Continued to Sheet No. 8.1.4)

(Continued from Sheet No. 8.1.3)

Terms and Conditions (Continued):

5. Lakeland Electric will furnish service under this rate at a single voltage through one point of delivery and measured through one meter. Equipment to supply additional voltages or additional facilities for the use of the customer shall be furnished and maintained by the customer.
6. Customers taking service under this interruptible rate schedule who desire to transfer to a non-interruptible rate schedule will be required to give Lakeland Electric written notice at least sixty (60) months prior to such transfer. Such notice shall be irrevocable unless Lakeland Electric and the customer mutually agree to void the revocation. Transfer to another interruptible rate schedule for which the customer is eligible is not subject to this notice provision.
7. So long as the customer remains eligible for service under this rate schedule Lakeland Electric shall not terminate service without sixty (60) months' written notice.
8. Customers requesting service under this interruptible rate schedule must have a minimum of 500 kW of demand that is available for interruption during the utility's peak or emergency conditions.
9. In the event the customer fails to deliver the specified interruptible load, billing adjustments will be made, back to the most recent interruption by Lakeland Electric, to remove the Controlled Demand Credit. The adjustment shall be billed at a rate 1.25 times the Controlled Demand Credit. The customer shall be ineligible for the Controlled Demand Credit until the ability to deliver the agreed interruptible load is demonstrated.
10. Controlled Demand Credit is defined as the amount recognized by Lakeland Electric as available for interruption.
11. Lakeland Electric may purchase power and energy from other sources for the customer's use during periods when interruptions are required but is not required to do so pursuant to this schedule. When possible, Lakeland Electric will provide advanced notification of purchases made for the customer or as soon as practical thereafter and similar notification will be provided upon termination of such purchases. The customer will be required to pay the actual charges of such purchases in lieu of the otherwise applicable energy charges (energy charge, capacity charge, and fuel adjustment) provided in this rate schedule. These costs shall be based on the customer's proportionate share of a higher cost of such purchased energy plus 1.04 mills per kWh. The cost of such purchased energy shall be based on the average cost of all purchased power and energy provided under this rate schedule during the corresponding calendar month.
12. Lakeland Electric, when possible, will provide advanced notification when interruptions are imminent or as soon as practical; thereafter, when advanced notice is not feasible.

**RATE SCHEDULE - ELDC
EXTRA LARGE DEMAND CUSTOMER**

Available:

In all territory served by Lakeland Electric.

Applicable:

To any general service customer whose highest 30-minute interval demand exceeds 5,000 kW in three (3) or more of the twelve (12) most recent monthly billing periods, including the current billing period.

Character of Service:

A-C; 60 Hertz; three-phase; at any standard utility voltage level of 69 KV or above.

Limitation of Service:

Not available for breakdown, standby, supplementary, or resale service.

Net Rate per Month:

Customer Charge:	\$557.00
Demand Charge:	\$12.13 per kW of Billing Demand
Energy Charge:	\$0.00225 per kWh

Minimum Bill:

Customer Charge, Facilities Charge, plus Adjustments.

Adjustments:

- a. Fuel Charge, as contained in Schedule BA-1
- b. City Utility Tax or Surcharge, taxes, surcharges, and fees as contained in Schedule BA-2
- c. Environmental Compliance Cost Charge as contained in Schedule BA-3

Payment:

Net bills are due when rendered and delinquent thirty (30) days after the billing date.

(Continued to Sheet No. 8.2.1)

(Continued from Sheet No. 8.2)

Discount applicable to service at 69 KV and above. A one percent (1.0%) discount shall apply to taxable fuel as specified in Schedule BA-2 and to the Environmental Compliance Cost Charge as specified in Schedule BA-3.

Determination of Billing Demand:

The billing demand for the month shall be the maximum 30-minute integrated kilowatt demand in the month.

Where charges specified in a rate schedule are based upon the measured maximum 30-minute integrated demand it is intended that such demand shall fairly represent the capacity which the Department is required to stand ready to supply. In case of installations which use this service in a manner such that measurement over a 30-minute interval does not result in a fair or equitable measure of the supply capacity required to serve the customer's load, then the measured demand may be adjusted taking into account the known character of use and the rating data of the equipment connected, or from special tests, the intent being that the demand so determined shall fairly represent the customer's capacity requirement.

In cases where Lakeland Electric elects to use connected load, instead of demand measurement, as the method for determining demand, it will consider the known character of use and the rating data of the equipment connected, the intent being that the demand so determined shall fairly represent the customer's capacity requirement.

Facilities Charge:

When the customer requires the utility to furnish and install special facilities for the exclusive use of the customer, such customer will be required to pay a facilities charge in addition to the above demand and energy rate. The facilities charge will be based upon the cost of such excess facilities.

Terms and Conditions:

1. All service hereunder will be supplied at one location through one point of delivery and measured through one meter.
2. The power factor at the time of the monthly peak demand must be maintained above 90 percent (90%).
3. Service hereunder is subject to the rules and regulations for electric service as adopted by Lakeland Electric from time to time and on file with the City Clerk.

**RATE SCHEDULE - ELDCX-1
EXTRA LARGE DEMAND CUSTOMER
SHIFT TO SAVE
OPTIONAL TIME OF DAY**

Available:

In all territory served by Lakeland Electric.

Applicable:

To any general service customer whose highest 30-minute interval demand exceeds 5,000 kW three (3) or more billing periods out of the twelve (12) most recent monthly billing periods including the current billing period.

Character of Service:

A-C; 60 Hertz; three-phase; at any standard utility voltage level of 69 KV or above.

Limitation of Service:

1. Resale not permitted under this rate schedule.
2. Customers taking service hereunder will be required to remain on this rate for a minimum initial period of twelve (12) consecutive months which shall continue for successive periods of twelve (12) months until terminated by written notice given by customer or Lakeland Electric.

Net Rate per Month:

Customer Charge: \$557.00
Demand Charge: \$12.13 per kW of Billing Demand
Energy Charge:
 On-Peak: \$0.0022487 per kWh
 Off-Peak: \$0.0022487 per kWh*

*The on-peak and off-peak are the same because the discount for off-peak is applied in the fuel tariff.

(Continued to Sheet No. 8.3.1)

(Continued from Sheet No. 8.3)

Definitions of the Time-of-Day Periods:

All time periods are stated in prevailing time.

	<u>Summer</u>	<u>Winter</u>
On-Peak Hours (Monday - Friday)	<u>Apr. 1 - Oct. 31</u> 12:01 PM - 9:00 PM	<u>Nov. 1 - March 31</u> 6:01 AM - 10:00 AM, and 6:01 PM - 10:00 PM

Off-Peak Hours All other weekday hours, and all hours on Saturdays, Sundays, New Year's Day, Memorial Day, Independence Day, Labor Day, Thanksgiving Day, and Christmas Day shall be off-peak.

Minimum Bill:

Customer Charge, Facilities Charge, plus Adjustments.

Payment:

Net bills are due when rendered and are delinquent thirty (30) days after the billing date.

Adjustments:

- Fuel Charge, as contained in Schedule BA-1
- City Utility Tax or Surcharge, taxes, surcharges, and fees as contained in Schedule BA-2
- Environmental Compliance Cost Charge as contained in Schedule BA-3

Discount Applicable to Service at 69 KV and Above:

A one percent (1.0%) discount shall apply to taxable fuel as specified in Schedule BA-2 and to the environmental compliance charge as specified in Schedule BA-3.

Determination of Billing Demand:

Billing demand is the maximum 30-minute interval demand established during the current on-peak period.

(Continued to Sheet No. 8.3.2)

(Continued from Sheet No. 8.3.1)

Where charges specified in a rate schedule are based upon the measured maximum 30-minute integrated demand, it is intended that such demand shall fairly represent the capacity which Lakeland Electric is required to stand ready to supply. In case of installations which use this service in a manner such that measurement over a 30-minute interval does not result in a fair or equitable measure of the supply capacity required to serve the customer's load, then the measured demand may be adjusted taking into account the known character of use and the rating data of the equipment connected or from special tests, the intent being that the demand so determined shall fairly represent the customer's capacity requirement.

In cases where Lakeland Electric elects to use connected load, instead of demand measurement, as the method for determining demand, it will consider the known character of use and the rating data of the equipment connected, the intent being that the demand so determined shall fairly represent the customer's capacity requirement.

Facilities Charge:

When the customer requires the utility to furnish and install special facilities for the exclusive use of the customer, such customer will be required to pay a facilities charge in addition to the above demand and energy rate. The facilities charge will be based upon the cost of such excess facilities.

Terms and Conditions:

1. All service hereunder will be supplied at one location through one point of delivery and measured through one meter.
2. The power factor at the time of the monthly peak demand must be maintained above 90 percent (90%).
3. Service hereunder is subject to the rules and regulations for electric service as adopted by Lakeland Electric from time to time on file with the City Clerk.

RATE SCHEDULE
NET METERING SERVICE

Available:

In all territory served by Lakeland Electric.

Applicable:

To Residential and Commercial Customers who construct and/or operate a photovoltaic array connected in parallel with Lakeland Electric's power distribution system (hereafter "System") through the customer's connection to the meter at or on the property; and there are no electrical safety, power quality, or other issues with such an installation.

Character of Service:

A-C; 60 Hertz; single- or three-phase; 120/240 volts, 120/208 volts or any other voltage offered by Lakeland Electric.

Limitation of Service:

1. To residential customers who install photovoltaic (PV) systems up to ten kilowatts (10-kW) in capacity (Tier 1), PV systems up to 100-kW in capacity (Tier 2), and to commercial customers who install PV systems up to two megawatts (2-MW) in capacity Tier 3). At present, there is no limit on the total net-metered capacity allowed in Lakeland Electric's service territory. This is subject to change at the sole discretion of Lakeland Electric.
2. The total size of the PV system may not exceed 100 percent (100%) of the customer's annual consumption.
3. If the total size of the PV systems exceeds 90 percent (90%) of the capacity of the transformer bank or service cables serving the property and/or if additional equipment is required, this will be at the customer's sole expense.
4. Falls within one of the following ranges:
Tier 1 – 10-kW or less;
Tier 2 - Greater than 10-kW and less than or equal to 100-kW, or,
Tier 3 – Greater than 100-kW and less than or equal to 2-MW.
5. Resale not permitted under this rate schedule.
6. Lakeland Electric reserves the right to limit the number of new customers served hereunder and service is subject to the availability of net metering equipment.
7. Customers taking service hereunder will be required to remain on this rate for a minimum initial period of twelve (12) consecutive months which shall continue for successive periods of twelve (12) months until terminated by written notice given by customer or Lakeland Electric.

Definitions:

1. Interconnection of a PV System - PV interconnection occurs when a solar powered generating system is installed on the customer side of the utility meter and operates in parallel with the utility's electrical service to the property. The energy produced by this generator is primarily intended to offset part or all of a customer's annual electricity requirements.
2. Net Metering - Lakeland Electric net metering is the condition where the energy being received from a customer-owned generator is metered separately from the energy being delivered to the customer and is credited back to the customer at the full retail rate.

(Continued to Sheet No. 8.4.1)

Issued by: Cynthia Clemmons
Manager of Legislative and Regulatory Relations

Effective Date: October 1, 2023

(Continued from Sheet No. 8.4)

Rules and Requirements:

To receive electric service under this Net Metering Service schedule, now, therefore, for and in consideration of the mutual covenants and agreements the customer hereby agrees as follows:

Lakeland Electric agrees that the photovoltaic generator, as specified in the "Application and Compliance Form," may be connected in parallel with the distribution system once the following conditions are met:

- a. The installation is in compliance with all provisions in the "Interconnection Requirements for Photovoltaic Systems" document, hereby made a part of this document.
 - b. Both parties have signed the "Hold Harmless/Indemnification" form.
 - c. The "Application and Compliance Form" document is completed and signed by the appropriate Electrical Inspector and Lakeland Electric.
2. This Agreement applies solely to customer's PV system at or on the property.
 3. Prior to operation, Lakeland Electric reserves the right to inspect the PV system installation to ensure compliance with the standards and codes noted in the "Interconnection Requirements for Photovoltaic Systems" document. If Lakeland Electric chooses to exercise this option, it agrees to inspect and, if the system is in compliance, provide written approval of the interconnection (using the Application and Compliance Form) within ten (10) working days following the request for inspection and approval. Parallel operation of the photovoltaic system with the grid shall not begin without Lakeland Electric's approval.
 4. Lakeland Electric reserves the right to refuse to accept electric power from the PV system under extreme conditions as described below. If Lakeland Electric chooses to exercise this option, which may involve physically disconnecting Lakeland Electric's system from the PV system, it agrees to make reasonable efforts to notify the customer when such conditions exist or are anticipated to exist, and to reconnect when the adverse conditions no longer exist. Examples of conditions that may lead to disconnection include:
 - a. City system emergencies and/or maintenance requirements,
 - b. Hazardous conditions existing on the PV system or its protective equipment,
 - c. Adverse effects of the PV system's operation on the Lakeland Electric System, or on other city customers, or
 - d. Failure of the PV system to comply with regulations, rules, orders or decisions of any government or regulatory authority having legal control over Lakeland Electric, generating equipment or operation.
 5. If the kWh delivered to the Lakeland Electric system exceeds the kWh delivered to the customer's load in a billing cycle, a credit for the net kWh delivered to Lakeland Electric's system shall be carried forward to the next billing cycle. Credits may accumulate and be carried forward for a moving 12-month period. The moving 12-month period is defined as ending in the current billing cycle and starting same month last year plus one month. In no event shall the customer be paid for excess energy delivered to the Lakeland Electric system at the end of the 12-month moving period.
 6. The customer acknowledges that there may be green energy attributes, called Tradable Renewable Energy Credits, which are derived from the energy generated by these systems. Photovoltaic customers shall retain any Renewable Energy Certificates associated with the electricity produced by their customer-owned renewable generation equipment. Any additional meters necessary for measuring the total renewable electricity generated for the purposes of receiving Renewable Energy Certificates shall be installed at the customer's expense. Lakeland Electric does not require the installation of a second meter.
 7. City reserves the right to terminate this Agreement with or without cause with thirty (30) calendar days written notice.
 8. Any material default of this Agreement by the customer shall allow the city to immediately terminate this Agreement and disconnect the customer's PV system from city's system.

(Continued to Sheet No. 8.4.2)

(Continued from Sheet No. 8.4.1)

9. The customer agrees to immediately notify city in writing if the customer:
 - a. Sells the property.
 - b. Makes a change to the PV system.
 - c. Sells the PV system or a portion thereof.
 - d. Performs maintenance on the PV system that may have an impact on Lakeland Electric's system.
10. For Tier Two and Three, Lakeland Electric may require an Interconnection Study and require the customer to pay an Interconnection Study Charge. If an Interconnection Study is necessary, further design review, testing and additional equipment as identified in the study may be required at the customer's sole expense prior to Lakeland Electric approval.

Notice should be sent to:

LE Solar Team
Lakeland Electric Mail Code: LE-ED ENG
501 East Lemon Street
Lakeland, FL 33801
Phone: (863) 834 -4647
Email: solar@lakelandelectric.com

11. Insurance and Indemnification. The Customer shall provide proof of and maintain at all times a general liability insurance policy for personal and property damage in the amount of at least no more than \$1 million for Tier 2, and no more than \$2 million for Tier 3. It is recommended that Tier 1 customers carry an appropriate level of liability insurance. The customer shall properly execute the Indemnification Agreement in the exact form as provided and deliver it to Lakeland Electric upon submitting the Application and Compliance Form.

Special Provisions:

1. At each net metering location, the utility will replace the customer's existing meter with a meter that is equipped with two separate registers. This meter will record:
 - a. All energy being delivered to the property on one register, and,
 - b. All energy being received from the property on the second register.
2. It is the intention of the program that the customer shall be charged for all of the energy recorded on the first register and be issued a credit for all of the energy that is recorded on the second register. This credit will appear as a separate line item on the monthly bill.
3. The utility at its own cost may request the customer allow Lakeland Electric to install a second meter to register the total output of the solar PV generator for data collection purposes. It will be a non-billing meter.
4. Upon termination of service the customer will receive compensation at the full retail rate for any accumulated credit from the utility at that time. Under no circumstances will any credits be transferred to another location.

Terms and Conditions:

1. Service hereunder is subject to the rules and regulations for electric service as adopted by Lakeland Electric from time to time on file with the City Clerk.
2. Rates, minimum bill, adjustments and payment definitions and stipulations shall apply as prescribed in the appropriate standard rate schedule.

Issued by: Cynthia Clemmons
Manager of Legislative and Regulatory Relations

Effective Date: October 1, 2023

NET METERING SERVICE
INTERCONNECTION REQUIREMENTS FOR PHOTOVOLTAIC SYSTEMS

A. Definitions

1. A Tier 1 photovoltaic (PV) System is a solar electric generator with an array rating of 10 kW or less under standard operating conditions (SOC) of one thousand (1,000) watts/m² solar irradiance, nominal operating cell temperature, air mass 1.5, and ASTM standard solar spectrum.
2. A Tier 2 PV System is a solar electric generator with an array rating of greater than 10 kW and less than or equal to 100 kW or less under SOC of 1000 watts/m² solar irradiance, nominal operating cell temperature, air mass 1.5, and ASTM standard solar spectrum.
3. A Tier 3 PV system is a solar electric generator with an array rating of greater than 100 kW and less than or equal to 2 megawatts (2MW) or less under SOC of 100/watts/ m² irradiance, nominal operating cell temperature, air mass 1.5, and ASTM standard solar spectrum.
4. The total size of PV system may not exceed 100 percent (100%) of the customer's annual consumption. If the total size of the PV systems exceeds 90 percent (90%) of the capacity of the transformer bank or service cables serving the Property and/or if additional equipment is required, this will be at the customer's sole expense.
5. An inverter, also referred to as a power conditioner, is a DC to AC device that converts PV energy to AC energy for utility interconnection. The inverter contains many control functions, such as voltage and frequency monitoring and protection against islanding. These Interconnection Requirements apply only to static inverters. Rotating devices cannot be used.

B. Standards and Codes

1. Inverter(s) - The inverter(s) must be listed and in compliance with Underwriters Laboratories (UL) Subject 1741 (2005), Standard for Static Inverters and Charge Controllers for Use in Photovoltaic Systems. Utility-interactive inverters that pass the tests of the new UL 1741 standard will be, by definition, "non-islanding" inverters and will comply with all elements of the IEEE 1547-2003 interconnection standard. The 1999 National Electrical Code requires that all utility-interactive photovoltaic systems use listed inverters that pass UL 1741 (2005).
2. PV Modules and Panels
 - a. PV modules and panels must be listed and be in compliance with Underwriters Laboratories (UL) Standard 1703, Standard for Safety: Flat-Plate Photovoltaic Modules and Panels.
 - b. PV modules must be in compliance with IEEE Standard 1262-1995, IEEE Recommended Practice for Qualification of Photovoltaic (PV) Modules (or, equivalently, IEC 61215).
3. System Installation - The installed system must be in compliance with: a) IEEE 1547-2003, Standard for Interconnecting Distributed Resources with Electric Power Systems, and b) all relevant articles of the 1999 National Electrical Code (or subsequent revisions).
4. External Disconnect Switch - Lakeland Electric requires a manual, lockable, load break utility-interface disconnect switch between the output of the photovoltaic inverter and the customer's wiring connected to Lakeland Electric's distribution system. The load break device shall be both visible and accessible to Lakeland's employees. Customer hereby grants a full license to access the property and the PV system to ensure compliance herewith.

(Continued on Sheet No. 8.5.1)

(Continued from Sheet No. 8.5)

5. Testing of Protective Relays - City reserves the right to test the anti-islanding features and the power output quality of the inverter.
6. PV System Equipment Protection - It is the responsibility of the customer to protect its generating equipment, inverters, protection devices, and other system components from damage by the normal conditions and operations that occur on the part of city in delivering and restoring System power. The city hereby disclaims any liability whatsoever for damage to the customer's equipment.
7. Metering Arrangements - The PV Inverter output will be connected, by the customer, to the customer side of the normal service meter through an External Disconnect Switch. The normal service meter shall be replaced with a meter that will measure and register power flowing into the customer's property and measure and register power flowing from the customer's resource into the Lakeland Electric system. The utility at its own cost, may request the customer allow Lakeland Electric to install a second meter to register the total output of the solar PV generator for data collection purposes. It will be a non-billing meter.

**NET METERING SERVICE
APPLICATION, COMPLIANCE FORM, AND AGREEMENTS**



Agreement for parallel connection of a Photovoltaic Generator and/or an Energy Storage System (PV-ESS) up to 2MW with the City of Lakeland's Electric Distribution System

This Agreement is made and entered into this ____ day of _____, 20____, by and between, the City of Lakeland, Florida on behalf of its municipal utility, Lakeland Electric ("LE") and _____ (the "Customer"), whose address is _____ (the "Property").

Whereas, LE endeavors to encourage the development of electric power generation using renewable fuels; and

Whereas, the Customer desires to construct and/or operate a PV-ESS connected in parallel with LE's power distribution system (hereafter "Grid") through the Customer's connection to the meter at or on the Property; and

Whereas, there are electrical safety, power quality, and other issues with such an installation.

Now, therefore, for and in consideration of the mutual covenants and agreements the parties hereby agree as follows:

1. Notify LE immediately if PV-ESS system is greater than 10kW.
2. The PV-ESS can only be connected in parallel with the LE distribution system once the following conditions are met:
 - a. The Customer provides written documentation that it has had a Final Electrical Inspection from the City/County.
 - b. The Customer and LE have signed this Agreement.
 - c. The installation is in compliance with all provisions in the attached Appendix A, hereby made a part of this Agreement.
 - d. Appendix B, attached hereto this Agreement is completed and signed by the parties identified in the application.
 - e. Appendix C, attached hereto has been signed by the Customer and notarized.
3. This Agreement applies solely to Customer's PV-ESS at or on the Property.

(Continued on Sheet No. 8.6.1)

(Continued from Sheet No. 8.6)

4. **LE's Inspection and Approval.** Prior to operation, LE reserves the right to inspect the PV-ESS installation to ensure compliance with the standards and codes noted in Appendix A. Upon inspection, if the system is in compliance, LE will provide written approval of the interconnection in accordance with Appendix B within ten (10) business days following the request for inspection and approval.

It may be necessary for LE to take, or request from the Customer, photographs of the Customer's PV-ESS system during the inspection.

Parallel operation of a PV-ESS with the Grid **shall not** begin without LE's final written approval.

5. For Tiers 2 & 3, as defined in Appendix A, LE may require an Interconnection Study and require the Customer to pay an Interconnection Study Charge. If an Interconnection Study is necessary, further design review, testing and additional equipment as identified in the study may be required at the Customers' sole expense prior to LE approval.

In no case shall the total size of all PV-ESS exceed 100% of the Customer's annual consumption. If the total size of the PV-ESS exceeds 90% of the capacity of the transformer bank or service cables serving the Property and/or if additional equipment is required, this will be at the Customer's sole expense.

6. All Customers installing PV-ESS systems are advised to schedule a PV Audit for their home before submitting an application to LE.
7. **Extreme Conditions.** LE reserves the right to refuse to accept electric power from the PV-ESS system under extreme conditions as described below. If LE chooses to exercise this option, which may involve physically disconnecting the Grid from the Customer's PV-ESS, it agrees to make reasonable efforts to notify the Customer when such conditions exist or are anticipated to exist, and to reconnect when the adverse conditions no longer exist. Examples of conditions that may lead to disconnection include, but may not be limited to:
 - a. LE System emergencies and/or maintenance requirements;
 - b. Hazardous conditions existing on the PV-ESS or its protective equipment;
 - c. Adverse effects of the PV-ESS system's operation on LE's Grid, or on other LE customers; or
 - d. Failure of the PV-ESS to comply with regulations, rules, orders or decisions of any government or regulatory authority having jurisdiction over LE, generating equipment or operation.
8. If the kWh delivered to LE's Grid exceeds the kWh delivered to the Customer's home in a billing cycle, a credit for the net kWh delivered to LE's Grid shall be carried forward to the next billing cycle. In no event shall the Customer be paid for excess energy delivered to LE's Grid. See Appendix D for additional information regarding pricing and rates.

(Continued on Sheet No. 8.6.2)

(Continued from Sheet No. 8.6.1)

9. PV-ESS Customers shall retain any Renewable Energy Certificates associated with the electricity produced by their customer-owned renewable generation equipment. Any additional meters necessary for measuring the total renewable electricity generated for the purpose of receiving Renewable Energy Certificates shall be installed at the Customer's sole expense.
10. LE reserves the right to terminate this Agreement with or without cause with thirty (30) calendar days' written notice.
11. Any material default of this Agreement by the Customer shall allow LE to immediately terminate this Agreement and disconnect the Customer's PV-ESS system from LE's Grid.
12. The Customer agrees to immediately notify LE, in writing, if any of the following occur to Customer:
 - a. Sells the Property;
 - b. Makes a change to the PV-ESS system;
 - c. Relocates the PV system as it requires LE's re-approval of the system, which in turn may require updated Engineer Drawings;
 - d. Sells/removes the PV-ESS system or a portion thereof; or
 - e. Performs maintenance on the PV-ESS system that may have an impact on the LE's Grid.

Change notice should be directed to:

LE Solar Team
Lakeland Electric Mail Code: LE- ED ENG
501 East Lemon Street
Lakeland, FL 33801
Phone: (863) 834 - 4647
solar@lakelandelectric.com

Insurance and Indemnification. The Customer shall provide proof of and maintain at all times a general liability insurance policy for personal and property damage in the amount of at least \$100,000. A standard homeowner's policy in at least this amount may meet this requirement. In addition, Customer shall properly execute the Indemnification Agreement in the exact form as attached as Appendix B and deliver it to LE upon submitting the Application set forth below.

By _____ Date: _____
Customer

By _____ Date: _____
City

(Continued on Sheet No. 8.6.3)

(Continued from Sheet No. 8.6.2)

APPENDIX A

INTERCONNECTION REQUIREMENTS FOR PHOTOVOLTAIC SYSTEMS LESS
THAN OR EQUAL TO 2MW

A. Standards and Codes

System Installation. The installed system must be in compliance with: a) *IEEE 1547-2003, Standard for Interconnecting Distributed Resources with Electric Power Systems* and b) all relevant articles of the *1999 National Electrical Code* (or subsequent revisions).

Inverter(s). Defined in Appendix A, the inverter(s) must be listed and in compliance with Underwriters Laboratories (UL) Subject 1741, Standard for Static Inverters and Charge Controllers for Use in Photovoltaic Systems. Utility-interactive inverters that pass the tests of the new UL 1741 standard will be, by definition, “non-islanding” inverters and will comply with all elements of the IEEE 1547-2003 interconnection standard. The 1999 National Electrical Code requires that all utility-interactive photovoltaic systems use listed inverters that pass UL 1741.

PV Modules and Panels. PV modules and panels must be listed and be in compliance with UL Standard 1703, Standard for Safety: Flat-Plate Photovoltaic Modules and Panels. PV modules must be in compliance with *IEEE Standard 1262-1995, IEEE Recommended Practice for Qualification of Photovoltaic (PV) Modules* (or, equivalently, IEC 61215).

Energy Storage System (ESS). ESS must be listed and be in compliance with UL Standard 1642, Standard for Lithium Batteries and Standard for Energy Storage Systems and Equipment.

External Disconnect Switch. LE requires a manual, lockable, load break utility-interface disconnect switch between the output of the photovoltaic inverter and any additional Customer owned energy sources, and the Customer’s wiring connected to LE’s Grid. The load break device shall be visible, accessible to Lakeland’s employees and, adjacent to existing utility meter. Customer hereby grants a full license to access the Property and the PV-ESS to ensure compliance herewith.

Metering Arrangements. The PV-ESS Inverter output must be connected, by the Customer, to the Customer side of the normal service meter through an External Disconnect Switch.

- a. The normal service meter shall be replaced with a meter that will measure and register power flowing into the Customer’s property and measure and register power flowing from the customer’s resource into the Grid.
- b. Upon completion and final acceptance of the Customer’s PV-ESS installation, LE will install these meters on the first day of the following billing cycle.

(Continued on Sheet No. 8.6.4)

(Continued from Sheet No. 8.6.3)

Testing of Protective Relays. LE reserves the right to test the anti-islanding features and the power output quality of the inverter.

PV System Equipment Protection. It is the responsibility of the Customer to protect its generating equipment, inverters, protection devices, and other system components from damage by the normal conditions and operations that occur on the part of LE in delivering and restoring System power. LE hereby disclaims any liability whatsoever for damage to the Customer's equipment.

B. Definitions

A **Tier 1 Photovoltaic (PV) System** is a solar electric generator with an array rating less than 10 kW under standard operating conditions (SOC) of 1000 watts/m² solar irradiance, nominal operating cell temperature, air mass 1.5, and ASTM standard solar spectrum.

A **Tier 2 Photovoltaic (PV) System** is a solar electric generator with an array rating greater than 10 kW and less than or equal to 100 kW under standard operating conditions (SOC) of 1000 watts/m² solar irradiance, nominal operating cell temperature, air mass 1.5, and ASTM standard solar spectrum.

A **Tier 3 Photovoltaic (PV) System** is a solar electric generator with an array rating greater than 100 kW and less than or equal to 2 MW under standard operating conditions (SOC) of 1000 watts/m² solar irradiance, nominal operating cell temperature, air mass 1.5, and ASTM standard solar spectrum.

An **Inverter**, also referred to as a *power conditioner*, is a dc to ac device that converts PV energy to ac energy for utility interconnection. The inverter contains many control functions, such as voltage and frequency monitoring and protection against islanding. These Interconnection Requirements apply only to static inverters. Rotating devices cannot be used.

(Continued on Sheet No. 8.6.5)

(Continued from Sheet No. 8.6.3)

**APPENDIX B
APPLICATION AND COMPLIANCE FORM
FOR PV-ESS LESS THAN 2MW**

A. Applicant Information	
Customer Name _____	Telephone # _____
Mailing Address _____	Email _____
City _____, FL _____	ZIP Code _____
Service address if different from mailing address _____	City _____
City account number _____	

(Continued on Sheet No. 8.6.6)

(Continued from Sheet No. 8.6.5)

B. Photovoltaic and Energy Storage System Information	
PV System Name/Model: _____	
PV Array DC Power at SOC in watts _____	
PV Array manufacturer and model _____	
PV Inverter manufacturer and model _____	
PV Array location _____	
PV Inverter location _____	
ESS Name/Model _____	
ESS DC Power at SOC in watt-hours _____	
ESS manufacturer and model _____	
ESS Inverter manufacturer and model _____	
ESS location _____	
AC Disconnect Location _____	
C. Installation Contractor Information	
_____	_____
Installation contractor name	FL license #
_____	_____
Contractor address	City, State, ZIP
_____	_____
Contractor phone	Email

Proposed installation date	

(Continued on Sheet No. 8.6.7)

(Continued from Sheet No. 8.6.8)

STATE OF: _____

COUNTY OF: _____

The foregoing instrument was acknowledged before me this ____ day of _____, 20__.

by _____, of _____.

Printed Name of Owner / Officer

Address

He/She is personally known to me or has produced _____ as
State Driver's License Number

identification, and did _____ / did not _____ take an oath.

Signature of Person Taking Acknowledgment

Printed Name of Person Taking Acknowledgment

Title

Serial Number, if any

Notary Seal

(Continued on Sheet No. 8.6.10)

(Continued from Sheet No. 8.6.9)

APPENDIX D

Residential Service Demand Rate (RSD)

Effective January 1, 2016, Lakeland Electric customers who choose to install photovoltaic (PV) solar panels on their home will be assigned to the Residential Service Demand (RSD) price plan¹.

The RSD plan is a combination of two things: 1) a peak demand charge (per kilowatt) that is only applied during a defined peak period and 2) a lower energy rate (per kilowatt-hour). Customers on the new RSD plan can benefit by:

- lessening their demand during specified peak periods and
- paying a lower energy rate at all times.

The RSD monthly bill is calculated using the Customer's total kilowatt-hour consumption plus the customer's highest demand during the peak period.

Additional information regarding the RSD price plan is available at Lakeland Electric Customer Service (863-834-9535) or on the Lakeland Electric website.

Go to <https://lakelandelectric.com/Solar#1802297-solar-price-plan> or go to *Customers » Programs & Services » ReEnergize Lakeland » Solar*, on our website.

Commercial Demand Rate (CD)

Effective January 1, 2016, Lakeland Electric Commercial and Industrial customers who choose to install photovoltaic (PV) solar panels on facilities not classified as residential homes will be assigned to one of the Commercial Demand (CD) price plans.¹

Commercial Customers have the potential to see lower electric bills with our Shift-to-Save price plan. With this program, companies receive a reduced rate when using electricity during "off-peak" times when Lakeland Electric's total Customer demand for power is lowest. Rates are based on the maximum amount of electricity your company uses during specific time periods.

A CD monthly bill is calculated using the customer's total kilowatt-hour consumption plus the customer's highest demand during the peak period.

Additional information regarding the CD price plans is available at Lakeland Electric Customer Service (863-834-9535) or on the Lakeland Electric website.

Go to <https://lakelandelectric.com/Customers/Pick-A-Plan/Price-Plans>

Please note that this information updated a regular basis and the pricing plan is subject to change based on Lakeland Electric's tariff which can be found at <https://lakelandelectric.com> under *Customers » Pick a Plan » Pricing Plans* and click on "[Rate Tariffs](#)"

(Continued on Sheet No. 8.6.11)

(Continued from Sheet No. 8.6.10)

E60SMSLR01

LAKELAND ELECTRIC
 SOLAR METERING CONFIGURATION

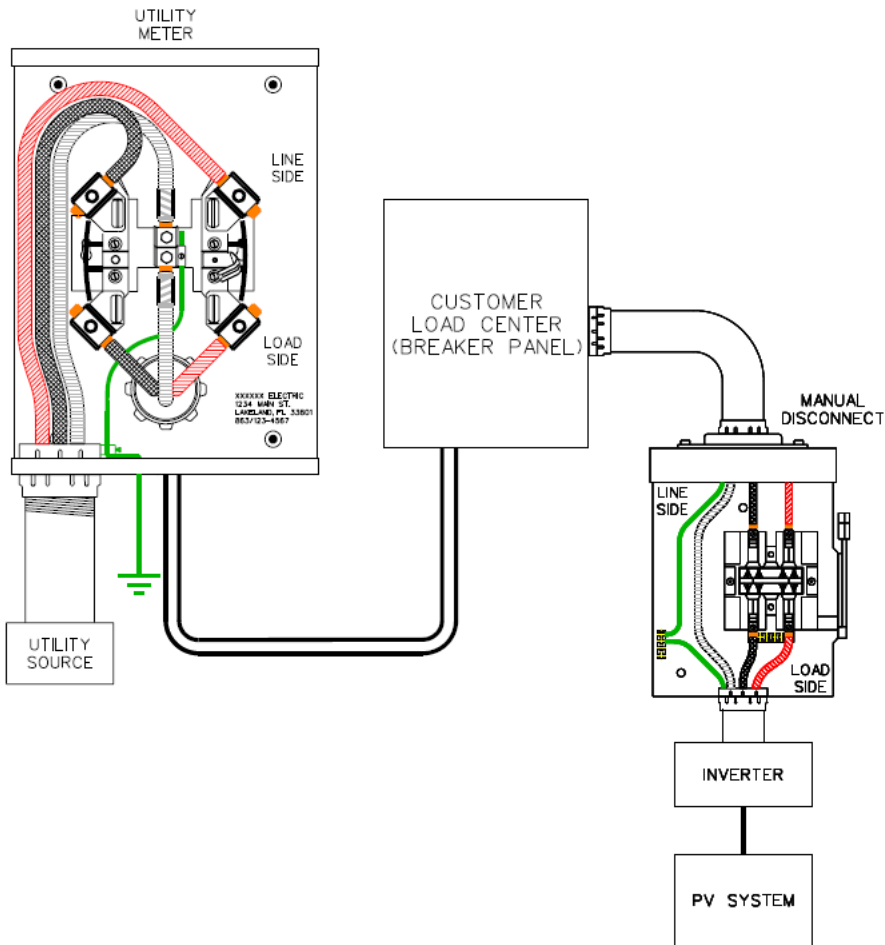

NOTES:

1. UTILITY INTERCONNECT POINT IS ON THE SOLAR METER LOAD SIDE LUG.
2. CUSTOMER CONNECTION FROM THE PV SYSTEM DISCONNECT SWITCH IS ON THE METER LINE SIDE LUG.
3. NEUTRAL CONNECTIONS ARE NOT MADE IN THE SOLAR METER CAN.
4. METER CANS AND DISCONNECT SWITCH BOXES SHALL BE PROPERLY GROUNDED.
5. WHILE ENTRY POINTS MAY DIFFER THAN SHOWN, TERMINATIONS SHALL BE MADE IN THE SPECIFIED LOCATIONS.
6. MANUAL DISCONNECT SWITCHES SHALL BE LOCATED ON THE EXTERIOR OF THE STRUCTURE.
7. SERVICE MUST UTILIZE PROPER CONDUIT, BUSHINGS, AND CONNECTORS.
8. THE UTILITY BILLING METER CAN SHALL NOT BE USED AS A PASSTHROUGH OR HAVE ANY ADDITIONAL CONNECTIONS MADE INSIDE IT.

E60SMSLR01.DGN

JMF 10/25/19
 BRS 01/29/19
 XXX 99/99/99

METERING

608

(Continued on Sheet No. 8.6.12)

(Continued from Sheet No. 8.6.11)

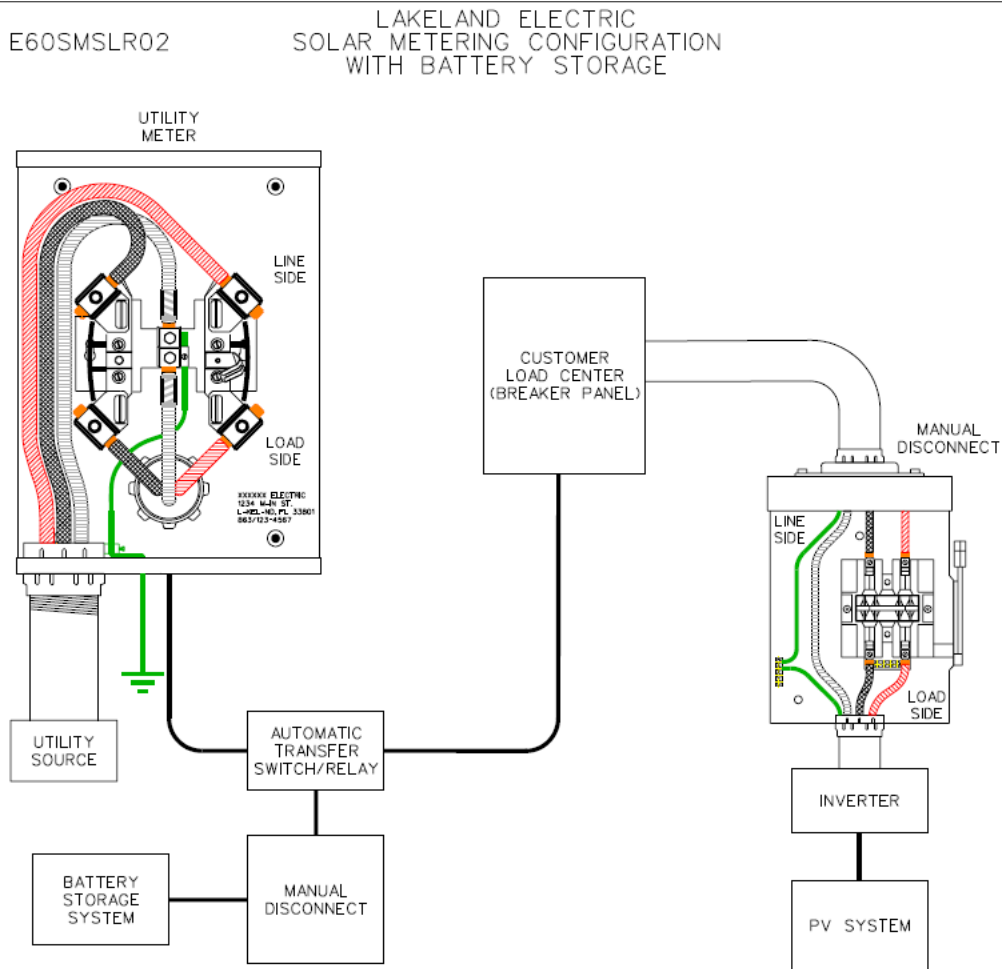

NOTES:

1. CUSTOMER CONNECTION FROM THE PV SYSTEM DISCONNECT SWITCH IS ON THE METER LINE SIDE LUG.
2. NEUTRAL CONNECTIONS ARE NOT MADE IN THE MANUAL DISCONNECT.
3. METER CANS AND DISCONNECT SWITCH BOXES SHALL BE PROPERLY GROUNDED.
4. WHILE ENTRY POINTS MAY DIFFER THAN SHOWN, TERMINATIONS SHALL BE MADE IN THE SPECIFIED LOCATIONS.
5. MANUAL DISCONNECT SWITCHES SHALL BE LOCATED ON THE EXTERIOR OF THE STRUCTURE.
6. SERVICE MUST UTILIZE PROPER CONDUIT, BUSHINGS, AND CONNECTORS.
7. THE UTILITY BILLING METER CAN SHALL NOT BE USED AS A PASSTHROUGH OR HAVE ANY ADDITIONAL CONNECTIONS MADE INSIDE IT.

E60SMSLR02.DGN

JMF 10/25/19
 BRS 01/29/19
 XXX 99/99/99

METERING

608

(Continued on Sheet No. 8.6.13)

(Continued from Sheet No. 8.6.12)

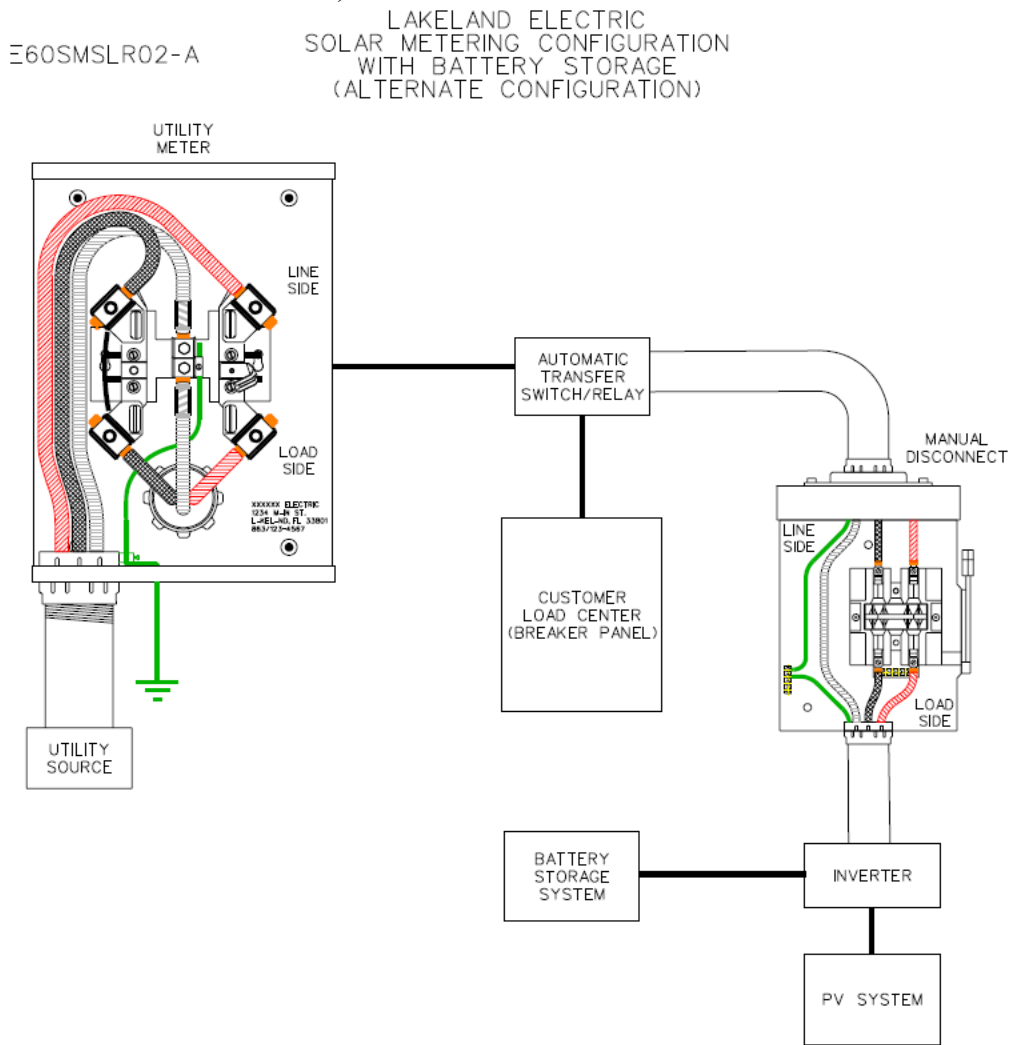

NOTES:

1. CUSTOMER CONNECTION FROM THE PV SYSTEM DISCONNECT SWITCH IS ON THE METER LINE SIDE LUG.
2. NEUTRAL CONNECTIONS ARE NOT MADE IN THE MANUAL DISCONNECT.
3. METER CANS AND DISCONNECT SWITCH BOXES SHALL BE PROPERLY GROUNDED.
4. WHILE ENTRY POINTS MAY DIFFER THAN SHOWN, TERMINATIONS SHALL BE MADE IN THE SPECIFIED LOCATIONS.
5. MANUAL DISCONNECT SWITCHES SHALL BE LOCATED ON THE EXTERIOR OF THE STRUCTURE.
6. SERVICE MUST UTILIZE PROPER CONDUIT, BUSHINGS, AND CONNECTORS.
7. THE UTILITY BILLING METER CAN SHALL NOT BE USED AS A PASSTHROUGH OR HAVE ANY ADDITIONAL CONNECTIONS MADE INSIDE IT.

JMF 10/25/19
 BRS 01/29/19
 XXX 99/99/99

METERING
 608

E60SMSLR02.DGN

RATE SCHEDULE - SS-1
FIRM SUPPLEMENTAL AND STANDBY

Available:

In all territory served by Lakeland Electric where system facilities are adequate and appropriate to provide service.

Applicable:

To any general service customer with electric generation facilities used to provide electricity for internal power requirements and requiring firm standby and supplemental electric service. This rate is not applicable to the following customers:

1. Whose electric generation is for emergency or testing purposes only
2. Whose onsite generating capability is less than 20-percent (20%) of the total onsite load
3. Onsite generating capability is less than 100 kW

Service under this schedule is also available to any specific generation customer who does not satisfy the provisions above and to whom providing service, in Lakeland Electric's opinion would be beneficial to its other customers.

Character of Service:

A-C; 60 Hertz; three-phase, at any standard utility voltage level offered by Lakeland Electric.

Limitations of Service:

1. Energy provided under this tariff is not available for resale.
2. Customers provided service under this tariff must sign a tariff agreement for the purchase of firm standby and supplemental service.
3. Should supplemental and standby service be provided one under the firm rate, and the other under the interruptible rate, separate meters will be required for each.
4. Service hereunder will be supplied at one location through one point of delivery and measured through one meter unless otherwise deemed necessary by Lakeland Electric.

Temporary Discontinuance of Service:

Where the use of energy is seasonal or intermittent, no adjustments will be made for a temporary discontinuance of service. Any customer prior to resuming service within 12 months after such service was discontinued will be required to pay all charges which would have been billed if service had not been discontinued.

(Continued to Sheet No. 8.7.1)

(Continued from Sheet No. 8.7)

Net Rate Per Month:

Supplemental Service

Will be served at Lakeland Electric's otherwise applicable rate.

Maintenance and Back-Up Charges

Customer Charge:	\$557.00
Reservation Charge: Monthly	\$1.54 per kW of Contract Standby Billing Demand
Daily Demand Charge:	\$0.76 per kW day of actual demand
Local Distribution Charge:	\$3.32 per kW of Contract Standby Billing Demand
Note:	Local Distribution Charge is not applicable when electric service is provided solely from the transmission system.
Energy Charge	\$0.00243 per kWh \$0.00429 per kWh (On-Peak Time of Day) \$0.00123 per kWh (Off-Peak Time of Day)

Definitions of the Time-of-Day Periods:

All time periods stated in prevailing time.

	<u>Summer</u>	<u>Winter</u>
	<u>Apr. 1 - Oct. 31</u>	<u>Nov. 1 - March 31</u>
On-Peak Hours (Monday - Friday)	12:01 PM - 9:00 PM	6:01 AM - 10:00 AM, and 6:01 PM - 10:00 PM
Off-Peak Hours	All other weekday hours, and all hours on Saturdays, Sundays, New Year's Day, Memorial Day, Independence Day, Labor Day, Thanksgiving Day, and Christmas Day shall be off-peak.	

Minimum Bill:

Customer charge, reservation charge, facilities charge plus Adjustments.

The billing demand charge for all kW up to the maximum contracted standby requirements for each month will be billed at the maximum of:

\$4.71 per kW-month times the contracted standby demand requirements (reservation charge) or \$0.74 per kW-day of actual standby demand delivered.

All kW between the actual standby demand and the contract demand will be billed at \$4.71 per kW-month.

(Continued to Sheet No. 8.7.2)

(Continued from Sheet No. 8.7.1)

Payment:

Net bills are due when rendered and delinquent 30 days after the billing date.

Adjustments:

Fuel charge, as contained in Schedule BA-1
City Utility Tax or Surcharge, taxes, surcharges, and fees as contained in Schedule BA-2
Environmental Compliance Cost Charge as contained in Schedule BA-3

Determination of Billing Demand:

Contract Standby Demand - Established in the tariff agreement for electric service provided under Rate Schedule SS-1, the demand contracted shall not exceed the net dependable capability of the customer's generating equipment. This demand will remain constant unless agreed to by mutual consent and appropriate changes are made to the tariff agreement and the agreement executed by both parties.

Standby Billing Demand - Is defined as the summation of the maximum integrated thirty (30) minute standby demand delivered by Lakeland Electric each day of the billing period. Standby demand for each thirty (30) minute period is the integrated thirty (30) minute demand delivered by Lakeland, but not exceeding the difference between the contract standby demand and the thirty (30) minute integrated kW output of the customer's generating unit(s), but never less than zero.

Supplemental Demand - Determined for each 30-minute interval as the net 30-minute integrated demand delivered by Lakeland Electric minus the standby demand for the 30-minute period.

Supplemental Billing Demand - Supplemental billing demand for the month shall be the maximum 30-minute integrated "Supplemental Demand" for the month. It is intended that this demand shall fairly represent the capacity which the Department is required to stand ready to supply in excess of the customer's generating capacity.

Installations which use this service in a manner such that measurement of a 30-minute interval does not result in fair or equitable measure of the supply capacity required to serve the customer's load, then the measured demand may be adjusted taking into account the known character of use and the rating data of the equipment connected or from special tests. It is the intent of this provision that the demand billed shall fairly represent the customer's capacity requirement. In cases where Lakeland Electric elects to use connected load instead of demand measurement as the method for determining demand, it will take into account the known character of use and the rating data of the equipment connected.

Primary Voltage Service:

Service at primary voltage, where available, will be supplied under this rate schedule upon request. When service is supplied at primary voltage, the customer will own and maintain all substations, lines, transformer supporting structures, transformers and other equipment required for utilization of the delivery voltage. Lakeland Electric will own no equipment beyond the primary voltage metering point. A twenty-six cent (\$0.26) discount on demand charge and a one-percent (1%) discount on energy, plus taxable fuel as specified in Schedule BA-2 charges and on the Schedule BA-3 charge will be allowed when service is delivered and metered at primary voltage.

(Continued to Sheet No. 8.7.3)

(Continued from Sheet No. 8.7.2)

Facilities Charge:

When the customer requests and the utility agrees to furnish and install special facilities for the exclusive use of the customer, such customer will be required to pay a monthly facilities charge in addition to the above demand and energy rate. The facilities charge will be based upon the actual cost of such excess facilities.

Terms and Conditions:

1. Power factor at the time of the monthly peak demand must be maintained above 90-percent (90%).
2. Service hereunder is subject to the rules and regulations for electric service as adopted by Lakeland Electric from time to time and on file with the City Clerk.
3. Service hereunder will be supplied at one location through one point of delivery and measured through one meter unless otherwise deemed necessary by Lakeland Electric.
4. Customers electing to receive service under this rate tariff are required to provide a 60-month notice, in writing, prior to transferring from this firm supplemental and standby service to any of Lakeland Electric's firm full requirements service.

RATE SCHEDULE - EDIR-1
ECONOMIC DEVELOPMENT RIDER ONE

Available:

In all territory served by Lakeland Electric.

Applicable:

This Rider is available for load associated with initial service to new customers or the expansion of existing customers taking service under one of the following rate schedules: General Service Demand (GSD), General Service Demand Shift to Save Optional Time-of-Day (GSX-2), General Service Large Demand (GSLD), General Service Large Demand Shift to Save Optional Time-of-Day (GSX-3), Extra Large Demand Customer (ELDC), or Extra Large Demand Customer Shift to Save Optional Time-of-Day (ELDCX-1).

Customers who desire service under Economic Development Rider One (EDIR-1) must enter into a service agreement with Lakeland Electric. The new load applicable under this Rider must be a minimum of 350 kW at a single delivery point. To qualify for service under this Rider, the customer must employ an additional work force of at least 25 full-time employees per 350 kW of new load and comply with all provisions in the service agreement.

The load and employment requirements under the Rider must be achieved at the same delivery point. The customer shall be responsible for Facilities Charges for additional metering equipment that may be required to qualify for this Rider.

The customer's service agreement under this Rider must include a description of the amount and nature of the load being provided, the number of full-time jobs resulting, and documentation verifying that Rider EDIR-1 is a significant factor in the customer's location/expansion decision.

Limitations of Service:

1. Lakeland Electric reserves the right to limit applications for this Rider at its discretion.
2. This Rider is also not available for renewal of service following interruptions such as equipment failure, temporary plant shutdown, strike, or economic conditions.
3. This Rider is also not available for load shifted from one establishment or delivery point on the Lakeland Electric system to another on the Lakeland Electric system.
4. A new customer may not make application under Rider EDIR-1 for load acquired from an existing customer. However, if a change in ownership occurs after the customer contracts for service under this Rider, the successor customer may be allowed to fulfill the balance of the contract under Rider EDIR-1 and continue the schedule of credits outlined below.

Definition:

New Load: New Load is load that is added to the Lakeland Electric's system by a new General Service (GS) customer or by an existing customer who expands its operations and increases demand, i.e. the net incremental load above that which existed prior to the service agreement.

(Continued to Sheet No. 8.8.1)

(Continued from Sheet No. 8.8)

Discount:

A credit based on the percentages below will be applied to the Demand Charge and base Energy Charge of the Customer's otherwise applicable rate schedule associated with the Customer's New Load:

- Year 1 – 25 percent (25%) reduction in demand and energy charges*
- Year 2 – 20 percent (20%) “
- Year 3 – 15 percent (15%) “
- Year 4 – 10 percent (10%) “
- Year 5 – 5 percent (5%) “

* All other charges including Customer Charge, Fuel Charge, Smart Grid Project Implementation, and Environmental Compliance Cost Charge will be as stated in the otherwise applicable rate schedule.

Terms of Service:

1. The customer agrees to a five-year contract term. Service under this Rider will terminate at the end of the fifth year.
2. Lakeland Electric may terminate service under this Rider at any time if the customer fails to comply with the terms and conditions of this Rider.
3. Failure to verify performance and to:
 - a. maintain the level of employment specified in the customer's service agreement and/or
 - b. purchase from Lakeland Electric the amount of load specified in the customer's service agreement may be considered grounds for early termination under this rider.

Provisions for Early Termination:

If Lakeland Electric terminates service under this Rider for the customer's failure to comply with its provisions, the customer will be required to reimburse Lakeland Electric for any discounts received under this Rider plus interest. If the customer opts to terminate service under this Rider before the term of service specified in the service agreement the customer will be required to reimburse Lakeland Electric for any discounts received under this Rider plus interest.

Rules and Regulations:

Service hereunder is subject to the rules and regulations for electric service as adopted by Lakeland Electric from time to time and on file with the City Clerk.

RATE SCHEDULE - EDIR-2
ECONOMIC DEVELOPMENT RIDER TWO

Available:

In all territory served by Lakeland Electric.

Applicable:

This Rider is available for load associated with initial service to new customers or the expansion of existing customers taking service under the General Service Rate (GS), General Service Business Demand Rate (GSBD) or General Service Shift to Save Optional Time-of-Day (GSX-1).

Customers who desire service under Economic Development Rider Two (EDIR-2) must enter into a service agreement with Lakeland Electric. The New Load applicable under this Rider must be a minimum of 5000 kWh and a load factor of 50 percent (50%) at a single delivery point. The Existing Load applicable under this Rider must be 50-percent (50%) additional consumption and a load factor of 50-percent (50%) at a single delivery point. To qualify for service under this Rider, the customer must employ an additional work force of at least five (5) full-time employees in the service territory with each salary at least 100-percent (100%) of the median annual wage for the Central Florida area.

The load and employment requirements under the Rider must be achieved at the same delivery point. The customer shall be responsible for Facilities Charges for additional metering equipment that may be required to qualify for this Rider.

The customer's service agreement under this Rider must include a description of the amount and nature of the load being provided, the number of full-time jobs resulting, and documentation verifying that Rider EDIR-2 is a significant factor in the customer's location/expansion decision.

Limitations of Service:

1. Lakeland Electric reserves the right to limit applications for this Rider at its discretion.
2. This Rider is also not available for renewal of service following interruptions such as equipment failure, temporary plant shutdown, strike, or economic conditions.
3. This Rider is also not available for load shifted from one establishment or delivery point on the Lakeland Electric system to another on the Lakeland Electric system.

Discount:

A credit based on the percentages below will be applied to the Energy and Demand (GSBD) Charge of the customer's otherwise applicable rate schedule associated with the customer's New Load:

(Continued to Sheet No. 8.9.1)

(Continued from Sheet No. 8.9)

Year 1 – 25-percent (25%) reduction in demand (GSBD) and energy charges*

Year 2 – 15-percent (15%) “

Year 3 – 5-percent (5%) “

* All other charges including Customer Charge, Fuel Charge, Smart Grid Project Implementation, and Environmental Compliance Cost Charge will be as stated in the otherwise applicable rate schedule.

Terms of Service:

1. The customer agrees to a three-year contract term. Service under this Rider will terminate at the end of the third year.
2. Lakeland Electric may terminate service under this Rider at any time if the customer fails to comply with the terms and conditions of this Rider.
3. Failure to verify performance and to:
 - a. maintain the level of employment specified in the customer’s service agreement and/or
 - b. purchase from Lakeland Electric the amount of load specified in the customer’s service agreement may be considered grounds for early termination under this rider.

Provisions for Early Termination:

If Lakeland Electric terminates service under this Rider for the customer’s failure to comply with its provisions, the customer will be required to reimburse Lakeland Electric for any discounts received under this Rider plus interest. If the customer opts to terminate service under this Rider before the term of service specified in the service agreement the customer will be required to reimburse Lakeland Electric for any discounts received under this Rider plus interest.

**RATE SCHEDULE - OL
 PRIVATE AREA LIGHTING**

Available:

In all territory served by Lakeland Electric.

Applicable:

For automatic outdoor lighting of public and/or private areas.

Character of Service:

Dusk-to-dawn lighting service.

Limitation of Service:

Installations shall be made only when, in the sole judgment of Lakeland Electric, the location of the proposed fixture is, and will continue to be, easily and economically accessible to equipment and personnel for both construction and maintenance.

Net Rate Per Month: Existing Pole - Overhead Wire

FIXTURE TYPE	Bill Codes	WATTS	LUMENS	CHARGE PER FIXTURE (\$)				KWH/MO. ASSUMED
				- Service Options ⁴ -				
				A.	B.	C.	D.	
High Pressure Sodium – Residential								
⁵ Closed to New Business								
Suburban	L70S	70	5800	0.98	3.15	1.71	7.07	31
Coachlight ¹	L70C	70	5800	0.96	3.96	1.71	7.86	31
Acorn ³ (Decorative)	L70A	70	5800	4.58	5.54	1.71	13.06	31
Coachlight ¹	L100C	100	9500	1.07	3.94	2.64	8.88	48
Suburban	L100S	100	9500	2.92	3.09	2.64	9.88	48
Roadway	L100R	100	9500	2.77	3.99	2.64	10.64	48
Directional	L100F	100	9500	2.93	4.21	2.64	11.01	48
Antique ² (Decorative)	L100T	100	9500	.98	6.73	2.64	11.58	48
Shoebox (Closed)	L100B	100	9500	4.88	5.82	2.64	14.57	48
Arlington ³ (Decorative)	L10AR	100	9500	2.82	5.58	2.64	12.27	48
Acorn ³ (Decorative)	L100A	100	9500	4.78	5.54	2.64	14.19	48
Granville ³ (Decorative)	L100G	100	9500	3.15	5.43	2.64	12.45	48
Granville Dark Skys ³	L10GD	100	9500	6.64	6.26	2.64	16.77	48
Coachlight ¹	L150C	150	16000	1.23	4.43	3.97	10.86	72
Roadway	L150R	150	16000	5.06	3.95	3.97	14.21	72
Suburban	L250S	250	27500	2.44	4.31	6.46	14.44	117
Roadway	L250R	250	27500	4.05	4.14	6.46	15.88	117
Directional	L250D	250	27500	6.12	5.46	6.46	19.27	117
Shoebox Sport – Single	L25SB	250	27500	8.52	6.49	6.46	22.70	117
Roadway	L400R	400	50000	10.20	4.43	8.93	24.79	162
Directional	L400D	400	50000	9.19	5.47	8.93	24.79	162
Shoebox Sport – Single	L40SB	400	50000	10.00	6.50	8.93	26.66	162

(Continued to Sheet No. 9.0.1)

(Continued from Sheet No. 9.0)

FIXTURE TYPE	BILL CODES	WATTS		CHARGE PER				KWH/MO. FIXTURE (\$)
		ASSUMED		LUMENS				
				- Service Options ⁴ -				
High Pressure Sodium – Commercial				A	B	C	D	
⁵ Closed to New Business								
Turnpike	L250T	250	21000	13.87	5.96	6.46	27.52	117
Turnpike	L400T	400	36000	13.61	5.97	8.93	29.74	162
Interstate	L400I	400	36000	14.19	7.69	8.93	32.04	162
Metal Halide – Commercial								
⁵ Closed to New Business								
Directional Flood	L25MD	250	21000	7.86	5.46	6.46	21.01	117
Shoebox Sports – Single	L2SBS	250	21000	8.90	6.11	6.46	22.70	117
Monument In Ground	L250G	250	21000	17.77	13.65	6.46	39.11	117
Shoebox Sports – Single	L4SBS	400	36000	9.44	6.51	8.93	26.11	162
Directional Flood	L40MD	400	36000	11.20	5.37	8.93	26.73	162
Standard Sports – Single	L10SS	1000	110000	14.40	1.82	19.63	37.08	356
Shoebox Sports – Single	L1SBS	1000	110000	15.89	8.71	19.63	45.46	356
Standard Sports – Single	L15SS	1500	155000	17.34	1.97	29.66	50.20	538
Shoebox Sports – Double	L1SBD	2000	220000	34.37	17.41	39.26	92.27	712
Standard Sports – Double	L10SD	2000	220000	25.00	5.44	39.26	70.93	712
Shoebox Sports – Triple	L1SBT	3000	330000	51.77	26.11	58.90	138.01	1068
Standard Sports – Triple	L10ST	3000	330000	41.49	10.88	58.90	112.50	1068
Standard Sports – Quad	L10SQ	4000	440000	51.55	18.12	78.53	149.43	1424
Shoebox Sports – Quad	L1SBQ	4000	440000	68.88	34.81	78.53	183.45	1424
LED								
Coachlight ¹	L10CL	52	9500	9.86	.78	.93	12.80	17
Suburban	L10SL	50	9500	6.01	.78	.93	8.95	17
Roadway	L10RL	50	9500	6.11	.78	.93	9.05	17
Directional	L10DL	50	9500	7.51	.78	.93	10.45	17
Arlington ³ (Decorative)	L1ARL	39	9500	15.64	1.13	.73	18.73	13
Acorn ³ (Decorative)	L10AL	39	9500	13.19	1.13	.73	16.28	13
Granville ³ (Decorative)	L10GL	39	9500	12.00	1.13	.73	15.09	13
Granville Dark Skys ³	L1GDL	39	9500	14.50	1.13	.73	17.59	13
Suburban	L25SL	70	27500	7.69	.78	1.27	10.97	23
Roadway	L25RL	130	27500	8.03	.78	2.37	12.41	43
Directional	L25DL	194	27500	14.64	.78	3.59	20.24	65
Shoebox Sport – Single	L25BL	130	27500	16.49	2.05	2.37	22.14	43
Roadway	L40RL	260	50000	10.94	.78	4.80	17.75	87
Directional	L40DL	266	50000	15.70	.78	4.91	22.62	89
Shoebox Sport – Single	L4SBL	260	50000	21.05	2.05	4.80	29.13	87

(Continue to Sheet No. 9.0.2)

(Continued from Sheet No. 9.0.1)

Municipal Fixtures Including Pole								
Solar (closed)	LS26	26	2100	68.67	25.01	0	94.91	12
Lake Mirror	L50T	50	4100	48.09	5.30	1.33	55.95	24
Lake Mirror	L70AT	70	5800	47.90	5.05	1.71	55.89	31
Street Scape Single	L70ST	70	5800	48.10	6.29	1.71	57.33	31
Street Scape Single	L15ST	100	9500	47.04	6.54	2.64	57.45	48
Street Scape Single	L10SC	150	16000	47.24	6.27	3.97	58.71	72
Street Scape Double	L14SC	140	14900	57.61	17.34	3.70	79.88	67
Contractor								
Single Pole	LSPC			6.08				
Double Pole	LDPC			7.19				
Pull Box	LPB			3.32				

Discrete Private Area Lighting Charges A, B, & C above, in any combination, are subject to a \$1.23 per month service charge.

¹ Used with the 16' Aluminum Pole

² Used with the 14' Fiberglass Pole

³ Used with the 13' Decorative Concrete Pole

⁴ Service Options

A. Fixture and Installation Only;

B. Maintenance of Fixture Only;

C. Energy, Excluding Fuel Charge, for Fixture Only; and

D. Full Service: The sum of each of the above Discrete Private Area Lighting Charges (A+B+C), plus the monthly service charge.

⁵Closed to New Business

Minimum Bill:

The sum of each of the discrete Private Area Lighting Charges plus the service charge.

Adjustments:

Fuel charge as contained in Schedule BA-1 (Fuel charge is applied to the assumed kWh per fixture)

City Utility Tax or Surcharge, taxes, surcharges, and fees as contained in Schedule BA-2

Environmental Compliance Cost Charge as contained in Schedule BA-3

Payment:

Net bills are due when rendered and are delinquent thirty (30) days after the billing date.

Term of Service:

Service under this rate shall be for minimum term of five (5) years for Decorative fixtures, all others shall be for a minimum term of three (3) years from the commencement of service and shall continue thereafter until terminated by either party by written notice thirty (30) days prior to termination. The customer may terminate such service prior to the expiration of minimum term by paying to Lakeland Electric, in one lump sum, the total amount of charges, excluding fuel charges, which would be payable during the remainder of the minimum term of service.

(Continued on Sheet No. 9.0.3)

(Continued from Sheet No. 9.0.2)

Special Provisions:

1. When a pole has been set exclusively for a light the following additional monthly charge will be made:

30' Wood Pole PW30	\$ 2.26	45' Commercial Spun Concrete PSC45	\$ 14.45
30' Concrete Pole (white) PC30	4.44	35' Commercial Concrete PC35C	8.14
16' Aluminum PA16	6.00	40' Commercial Concrete PC40C	12.40
14' Fiberglass Pole PF14	8.70	45' Commercial Concrete PC45C	13.57
13' Decorative Concrete PB13	10.57	50' Commercial Concrete PC50C	14.64
30' Commercial Bronze Aluminum P30BA	22.03	30' Commercial Aluminum & Arm P30AA	17.01
35' Commercial Blk Spun Concrete P35BC	14.40	40' Commercial Aluminum & Arm P40AA	20.84
40' Commercial Aluminum Tenon P40AT	23.08	40' Commercial Dbl Arm Alum P40DA	26.65
45' Commercial Aluminum P45A	18.21	50' Commercial Aluminum & Arm P50AA	22.84
50' Commercial Aluminum Tenon P50AT	37.60	50' Commercial Dbl Arm Alum. P50DA	28.09
50' Commercial Wood Class 3 PW50	6.26		

2. Lakeland Electric will furnish, install, and maintain approved street lighting luminaries and lamps and/or directional luminaries and lamps including integral automatic photocell controls, and will install same on existing Lakeland Electric owned poles. Installation will include one span of secondary wire, if necessary.
3. Damage to fixtures, lamps, or equipment while in use on the customer's property will be replaced or repaired by Lakeland Electric and such costs will be billed to the customer.
4. Underground wiring is available at extra cost to be determined by Lakeland Electric.
5. Customer desiring service under this rate will be required to sign a contract with Lakeland Electric.
6. Decorative light fixture installations including Acorn, Arlington, Antique, and Granville, will not be available on an individual basis, but will be limited to multiple installations at the discretion of Lakeland Electric. Lake Mirror and Streetscape Fixtures are available only for governmental agencies.

**RATE SCHEDULE - OL-1
 STREET AND ROADWAY LIGHTING**

Available:

In all territory served by Lakeland Electric.

Applicable:

For automatic outdoor lighting of public and private streets and roadways used for vehicular traffic.

Character of Service:

Dusk-to-dawn lighting service.

Limitation of Service:

Installations shall be made only when, in the judgment of Lakeland Electric, the location of the proposed fixture is, and will continue to be, easily and economically accessible to equipment and personnel for both construction and maintenance.

Net Rate Per Month: Existing Pole - Overhead Wire

FIXTURE TYPE	BILL CODES	WATTS	LUMENS	CHARGE PER FIXTURE (\$)				KWH/MO. ASSUMED
				- Service Options ⁴ -				
High Pressure Sodium – Residential				A.	B.	C.	D.	
⁵ Closed to New Business								
Suburban	L70S	70	5800	2.53	0.68	1.71	6.15	31
Coachlight ¹ (Decorative)	L70C	70	5800	3.04	0.89	1.71	6.87	31
Acorn ³ (Decorative)	L70A	70	5800	7.38	1.06	1.71	11.38	31
Coachlight ¹ (Decorative)	L100C	100	9500	2.97	0.92	2.64	7.76	48
Suburban	L100S	100	9500	4.34	0.41	2.64	8.62	48
Roadway	L100R	100	9500	4.74	0.66	2.64	9.27	48
Directional	L100F	100	9500	4.35	1.38	2.64	9.60	48
Antique ² (Decorative)	L100T	100	9500	5.00	1.23	2.64	10.10	48
Shoebox (Closed)	L100B	100	9500	6.60	2.25	2.64	12.72	48
Arlington ³ (Decorative)	L10AR	100	9500	5.69	1.12	2.64	10.68	48
Acorn ³ (Decorative)	L100A	100	9500	7.44	1.06	2.64	12.37	48
Granville ³ (Decorative)	L100G	100	9500	5.85	1.12	2.64	10.84	48
Granville Dark Skys ³	L10GD	100	9500	6.64	4.10	2.64	14.61	48
Coachlight ¹	L150C	150	16000	3.36	0.92	3.97	9.48	72
Roadway	L150R	150	16000	6.27	0.95	3.97	12.42	72
Suburban	L250S	250	27500	3.96	0.99	6.46	12.64	117
Roadway	L250R	250	27500	5.21	0.99	6.46	13.89	117
Directional	L250D	250	27500	7.81	1.33	6.46	16.83	117
Shoebox Sport – Single	L25SB	250	27500	9.84	2.29	6.46	19.82	117
Roadway	L400R	400	50000	10.75	0.76	8.93	21.67	162
Directional	L400D	400	50000	10.25	1.26	8.93	21.67	162
Shoebox Sport – Single	L40SB	400	50000	10.77	2.35	8.93	23.28	162

(Continued to Sheet No. 9.1.1)

(Continued from Sheet No. 9.1)

FIXTURE TYPE	BILL CODES	WATTS	LUMENS	CHARGE PER FIXTURE (\$)				KWH/MO. ASSUMED
				- Service Options ⁴ -				
High Pressure Sodium – Commercial								
⁵ Closed to New Business								
Turnpike	L250T	250	21000	A. 14.99	B. 1.33	C. 6.46	D. 24.01	117
Turnpike	L400T	400	36000	14.48	1.33	8.93	25.97	162
Interstate	L400I	400	36000	16.49	1.33	8.93	27.98	162
Metal Halide – Commercial								
⁵ Closed to New Business								
Directional Flood	L25MD	250	21000	7.97	2.69	6.46	18.35	117
Shoebox Sports – Single	L2SBS	250	21000	9.84	2.29	6.46	19.82	117
Monument In Ground	L250G	250	21000	19.31	7.09	6.46	34.09	117
Shoebox Sports – Single	L4SBS	400	36000	10.29	2.35	8.93	22.80	162
Directional Flood	L40MD	400	36000	9.58	3.61	8.93	23.38	162
Standard Sports – Single	L10SS	1000	110000	9.08	2.53	19.63	32.47	356
Shoebox Sports – Single	L1SBS	1000	110000	15.20	3.69	19.63	39.75	356
Standard Sports – Single	L15SS	1500	155000	10.48	2.64	29.66	44.01	538
Shoebox Sports – Double	L1SBD	2000	220000	27.55	12.66	39.26	80.70	712
Standard Sports – Double	L10SD	2000	220000	13.60	8.07	39.26	62.16	712
Shoebox Sports – Triple	L1SBT	3000	330000	33.66	26.94	58.90	120.73	1068
Standard Sports – Triple	L10ST	3000	330000	21.82	16.58	58.90	98.53	1068
Standard Sports – Quad	L10SQ	4000	440000	23.02	28.10	78.53	130.88	1424
Shoebox Sports – Quad	L1SBQ	4000	440000	34.20	46.51	78.53	160.47	1424
LED								
Coachlight ¹	L10CL	52	9500	8.58	0.68	0.93	11.42	17
Suburban	L10SL	50	9500	5.23	0.68	0.93	8.07	17
Roadway	L10RL	50	9500	5.31	0.68	0.93	8.15	17
Directional	L10DL	50	9500	6.53	0.68	0.93	9.37	17
Arlington ³ (Decorative)	L1ARL	39	9500	13.60	0.99	0.73	16.55	13
Acorn ³ (Decorative)	L10AL	39	9500	11.48	0.99	0.73	14.43	13
Granville ³ (Decorative)	L10GL	39	9500	10.43	0.99	0.73	13.38	13
Granville Dark Skys ³	L1GDL	39	9500	12.60	0.99	0.73	15.55	13
Suburban	L25SL	70	27500	6.69	0.68	1.27	9.87	23
Roadway	L25RL	130	27500	6.97	0.68	2.37	11.25	43
Directional	L25DL	194	27500	12.73	0.68	3.59	18.23	65
Shoebox Sport – Single	L25BL	130	27500	14.34	1.78	2.39	19.72	43
Roadway	L40RL	260	50000	9.52	0.68	4.80	16.23	87
Directional	L40DL	266	50000	13.66	0.68	4.91	20.48	89
Shoebox Sport – Single	L4SBL	260	50000	18.31	1.78	4.88	26.12	87

(Continued to Sheet No. 9.1.2)

(Continued from Sheet No. 9.1.1)

Municipal Fixtures Including Pole

Solar (closed)	LS26	26	2100	68.65	12.65	0	82.53	12
Lake Mirror	L50T	50	4100	43.88	1.23	1.33	47.67	24
Lake Mirror	L70AT	70	5800	44.01	1.23	1.71	48.18	31
Street Scape Single	L70ST	70	5800	43.50	2.22	1.71	48.66	31
Street Scape Single	L10SC	100	9500	43.51	2.22	2.64	49.60	48
Street Scape Single	L15ST	150	16000	43.67	2.22	3.97	51.09	72
Street Scape Double	L14SC	140	14900	56.71	7.88	3.43	69.25	62
Contactor								
Single Pole	LSPC			5.28				
Double Pole	LDPC			6.26				
Pull Box	LPB			2.89				

Discrete Street and Roadway Lighting Charges A, B, & C above, in any combination are subject to a \$1.23 per month service charge.

¹ Used with the 16' Aluminum Pole

² Used with the 14' Fiberglass Pole

³ Used with the 13' Decorative Concrete Pole

⁴ Service Options

A. Fixture and Installation Only;

B. Maintenance of Fixture Only;

C. Energy, Excluding Fuel Charge, for Fixture Only; and

D. Full Service: The sum of each of the above Discrete Street and Roadway Lighting Charges (A+B+C), plus the monthly service charge.

⁵Closed to New Business

Minimum Bill:

The sum of each of the discrete Street and Roadway Lighting Charges plus the service charge.

Adjustments:

Fuel charge as contained in Schedule BA-1 - (Fuel charge is applied to the Assumed kWh per fixture)

City Utility Tax or Surcharge, taxes, surcharges, and fees as contained in Schedule BA-2

Environmental Compliance Cost Charge as contained in Schedule BA-3

Polk County Public Service Tax and Florida State Sales Tax

Payment:

Net bills are due when rendered and are delinquent thirty (30) days after the billing date.

Term of Service:

Service under this rate shall be for minimum term of five (5) years for Decorative fixtures, all others shall be for a minimum term of three (3) years from the commencement of service and shall continue thereafter until terminated by either party by written notice thirty (30) days prior to termination. The customer may terminate such service prior to the expiration of minimum term by paying to Lakeland Electric, in one lump sum, the total amount of charges, excluding fuel charges, which would be payable during the remainder of the minimum term of service.

(Continued to Sheet No. 9.1.3)

Issued by: Cynthia Clemmons
Manager of Legislative and Regulatory Relations

Effective Date: October 1, 2025

(Continued from Sheet No. 9.1.2)

Special Provisions:

1. When a pole has been set exclusively for a light the following additional monthly charge will be made:

30' Wood Pole PW30	\$ 1.96	45' Commercial Spun Concrete PSC45	\$ 12.56
30' Concrete Pole (white) PC30	3.48	35' Commercial Concrete PC35C	7.08
16' Aluminum PA16	5.22	40' Commercial Concrete PC40C	10.77
14' Fiberglass Pole PF14	7.56	45' Commercial Concrete PC45C	11.80
13' Decorative Concrete PB13	9.19	50' Commercial Concrete PC50C	12.73
30' Commercial Bronze Aluminum P30BA	19.15	30' Commercial Alum. & Arm P30AA	14.80
35' Commercial Blk Spun Concrete P35BC	12.51	40' Commercial Aluminum & Arm P40AA	18.11
40' Commercial Aluminum Tenon P40AT	20.07	40' Commercial Dbl Arm Alum P40DA	23.18
45' Commercial Aluminum P45A	15.83	50' Commercial Aluminum & Arm P50AA	19.09
50' Commercial Aluminum Tenon P50AT	32.70	50' Commercial Dbl Arm Alum. P50DA	24.43
50' Commercial Wood Class 3 PW50	5.44		

- Lakeland Electric will furnish, install, and maintain approved street lighting luminaries and lamps and/or directional luminaries and lamps including automatic photocell controls, and will install same on existing Lakeland Electric owned poles. Installation will include one overhead span of secondary wire, if necessary.
- Fixtures, lamps, or equipment damaged in any way by the customer will be repaired or replaced by Lakeland Electric at the customer's sole cost and expense. Such costs will be billed to the customer.
- Underground wiring is available at extra cost to be determined by Lakeland Electric.
- Customer desiring service under this rate will be required to sign a contract with Lakeland Electric.
- Decorative light fixture installations, including Acorn, Arlington, Antique, and Granville, will not be available on an individual basis, but will be limited to multiple installations at the discretion of Lakeland Electric. Lake Mirror and Streetscape Fixtures are available only for governmental agencies.

**RATE SCHEDULE - BA-1
 FUEL CHARGE**

The charge for the fuel used to provide electric energy to all service schedules shall be a pass-through cost. This means that the actual per kilowatt hour price that the utility pays for fuel and purchased power shall be the same per kilowatt - hour price paid by the customers.

Fuel charges may be either levelized or a combination of On-Peak and Off-Peak charges, depending upon the rate schedule. The levelized fuel charge shall be calculated using the delivered cost of all fuel burned and the fuel cost of all interchanged power. On-Peak and Off-Peak fuel costs are based on a percentage of the levelized fuel rate and are calculated once per year, on or about January 1, to reflect the change in costs from one year to the next. Adjustments are made when the On-Peak percentage changes by more than five percentage points.

The Lakeland City Commission shall by resolution establish the fuel charge sufficient to fully recover the projected costs of fuel and purchased power over a twelve-month period.

No less than quarterly, the staff of Lakeland Electric shall determine Lakeland Electric's total projected fuel costs for the subsequent twelve-month period which shall be the projected fuel budget which shall include an amount sufficient to establish reserves in the amount of 15-percent (15%) of the annual projected fuel budget. This projected fuel budget shall consider projected system average fuel costs, projected energy generation, projected power purchases anticipated for that subsequent twelve-month period, and a 15% reserve component. To the extent the projected fuel budget results in a cumulative under-recovery of fuel costs, measured as of the end of the twelve-month period, in an amount exceeding 0.5 mills times the forecasted annual sales volume during the forecast period, the City Commission of the City of Lakeland shall, by resolution, amend the previously established fuel charge in an amount sufficient to fully recover the projected shortfall during the subsequent twelve-month period.

The applicable fuel charge for each rate class is listed below.

Rate Schedule	Fuel Charge		
	Levelized Rate	On-Peak	Off-Peak
RS Residential Service	X	-	-
RSX-1 Residential Service Shift to Save Optional Time-of-Day	-	X	X
RSD Residential Service Demand	X	-	-
GS General Service and Construction Power	X	-	-
GSX-1 General Service Shift to Save Optional Time-of-Day	-	X	X
GSBD General Service Business Demand	X	-	-
GSD General Service Demand	X	-	-
GSX-2 General Service Demand Shift to Save Optional Time-of-Day	-	X	X
GSLD General Service Large Demand	X	-	-
GSX-3 General Service Large Demand Shift to Save Optional Time-of-Day	-	X	X
ISX-1 General Service Interruptible Shift to Save Optional Time-of-Day	-	X	X
IS General Service Interruptible Rate	X	-	-
SS-1 Firm Supplemental and Standby – Time-of-Day Option	-	X	X
ELDCX-1 Extra Large Demand Customer Shift to Save Optional Time-of-Day	-	X	X
ELDC Extra Large Demand Customer	X	-	-

(Continued to Sheet No. 9.2.1)

(Continued from Sheet No. 9.2)

In accordance with Fuel charge BA-1, the tables that follow provide an accounting of several years of historical fuel changes:

Historical Levelized and Two-Period Shift-to-Save Fuel Charges						
Effective		Levelized Rate \$/kWh	On-Peak %	Off-Peak %	On-Peak \$/kWh	Off-Peak \$/kWh
Year	Month					
2018	APR	\$0.040750	118.8%	91.0%	\$0.048411	\$0.037083
2018	OCT	\$0.038750	118.8%	91.0%	\$0.046035	\$0.035263
2019	APR	\$0.037500	118.8%	91.0%	\$0.044550	\$0.034125
2019	JUL	\$0.036500	118.8%	91.0%	\$0.043362	\$0.033215
2019	OCT	\$0.032750	118.8%	91.0%	\$0.038907	\$0.029803
2020	JAN	\$0.032750	130.8%	86.1%	\$0.042837	\$0.028198
2020	APR	\$0.027000	130.8%	86.1%	\$0.035316	\$0.023247
2020	MAY	\$0.020000	130.8%	86.1%	\$0.026160	\$0.017220
2020	JUL	\$0.028000	130.8%	86.1%	\$0.036624	\$0.024108
2020	OCT	\$0.030000	130.8%	86.1%	\$0.039240	\$0.025830
2021	JAN	\$0.035000	124.2%	89.1%	\$0.043470	\$0.031185
2021	APR	\$0.040000	124.2%	89.1%	\$0.049680	\$0.035640
2022	JAN	\$0.040000	124.2%	89.1%	\$0.049680	\$0.035640
2022	JUL	\$0.060000	124.2%	89.1%	\$0.074520	\$0.053460
2022	SEP	\$0.075000	124.2%	89.1%	\$0.093150	\$0.066825
2023	MAR	\$0.055000	124.2%	89.1%	\$0.068310	\$0.049005
2023	OCT	\$0.045000	124.2%	89.1%	\$0.055890	\$0.040095
2024	JAN	\$0.038000	114.8%	93.7%	\$0.0436240	\$0.035606
2024	APR	\$0.036000	114.8%	93.7%	\$0.0413280	\$0.033732
2024	JUL	\$0.045000	114.8%	93.7%	\$0.0516600	\$0.042165
2024	OCT	\$0.043500	114.8%	93.7%	\$0.0499380	\$0.040760
2025	JAN	\$0.041500	122.1%	90.4%	\$0.0506715	\$0.037516
2025	SEP	\$0.043500	122.1%	90.4%	\$0.0531140	\$0.039324
2026	JAN	\$0.047000	122.1%	90.4%	\$0.0573870	\$0.042488
2026	APR	\$0.062000	122.1%	90.4%	\$0.0757020	\$0.056048

RATE SCHEDULE - BA-2
TAX AND SURCHARGE ADJUSTMENT

Lakeland Public Service Tax and Surcharge:

A ten-percent (10%) Utility Tax (inside city limits) or a ten-percent (10%) surcharge (outside city limits) shall be imposed against all customers, demand, energy charges, and environmental compliance cost charges contained in Lakeland Electric's electric rates.

The ten-percent (10%) Utility Tax (inside city limits) or ten-percent surcharge (10%) (outside city limits) shall be imposed only on Lakeland Electric's Base Fuel Cost as of October 1, 1973.

The amount of Lakeland Electric's Base Fuel Cost as of October 1, 1973, is \$0.004108 per kWh.

Any amount of fuel charge above the non-exempt fuel amount of \$0.004108 per kWh shall be excluded from the ten-percent (10%) utility tax or the ten-percent surcharge.

Florida Gross Receipts, Regulatory Trust Fund Tax Adjustment, and Florida State Sales Tax:

The Regulatory Trust Fund Tax Adjustment in a billing period shall be the actual tax level imposed for Florida Gross Receipts Tax and Public Service Commission Regulatory Trust Fund Tax to the nearest 0.0001% one ten-thousandth of a percent. This tax adjustment shall be levied on all revenue associated with the retail delivery of electricity under Lakeland Electric's published rate tariffs.

The Florida State Sales tax adjustment shall be applied in accordance with the appropriate Florida statutes exclusively for the purpose of collecting these taxes as levied by the State of Florida. Except for residential charges, all charges for electric service are subject to Florida State Sales Tax.

Polk County Public Service Tax:

The Tax Adjustment shall be the actual tax level imposed by Polk County against all customers, demand, energy charges, and environmental compliance cost charges contained in Lakeland Electric's electric rates.

The tax shall only be imposed on Lakeland Electric's Base Fuel Cost as of October 1, 1973, \$0.004108 per kWh. Any amount of fuel charge above the non-exempt fuel amount of \$0.004108 per kWh shall be excluded.

Franchise Fees:

A franchise fee of four-percent (4%) of gross revenues from the sale of electric energy shall be billed to customers who reside within the jurisdiction of Polk City.

**RATE SCHEDULE - BA-3
ENVIRONMENTAL COMPLIANCE COST CHARGE**

The Environmental Compliance Cost Charge (EC3) is to recover the cost of complying with environmental regulations where such costs are not included in other rate schedules. Acceptable costs for the EC3 include:

- In-service rate-funded environmental capital investments
- Debt service associated with the financing of debt-funded environmental projects
- Operating and Maintenance expenses necessary to meet environmental laws and regulations
- Fuel and purchase power costs not included in Rate Schedule BA-1
- Emission allowances

Rates shall be calculated annually. The City Commission shall by resolution establish the EC3. The annual rate change shall be effective with the first billing cycle of the fiscal year.

Actual expenses from the prior year shall be subject to true-up calculations.

The table below provides an historical accounting of recent environmental charges.

Historical Changes		
2015	Oct	\$0.0025329
2016	Oct	\$0.0025329
2017	Oct	\$0.0021099
2018	Oct	\$0.0021099
2019	Oct	\$0.0027763
2020	Oct	\$0.0028758
2021	Oct	\$0.0028758
2022	Oct	\$0.0024097
2023	Oct	\$0.0015907
2024	Oct	\$0.0011766
2025	Oct	\$0.0018506

RATE SCHEDULE - BA-5
SMART GRID PROJECT IMPLEMENTATION

The Smart Grid project implementation charge shall be \$0.00014 per kilowatt-hour (kWh) for electric energy provided under all service schedules except:

- ISX-1 (General Service Interruptible Shift to Save Optional Time-of-Day)
- IS (General Service Interruptible Rate)
- ELDC (Extra Large Demand Customer)
- ELDCX-1 (General Service Extra Large Demand Customer Shift to Save Optional Time-of-Day)
- SS-1 (Firm Supplemental and Standby),
- OL (Private Area Lighting)
- OL-1 (Street and Roadway Lighting)

The above charge is effective the first billing cycle of Fiscal Year 2011 and shall remain effective for a period of time not to exceed the term of bonds funding the project (15 years). Rate BA-5 shall be reviewed for inclusion in base rates by the first-rate study performed subsequent to full implementation of the Smart Grid project.

MEDICALLY ESSENTIAL SERVICE

The program is designed to provide Lakeland Electric customers who rely on electricity for life-sustaining equipment reasonable notification of power interruption due to scheduled maintenance or service disconnection.

To qualify for the Medically Essential Service Program, the customer must have their physician complete a form provided by Lakeland Electric stating they need electricity for life-sustaining equipment.

The City of Lakeland will not suspend electric and/or water service to a residential customer, at any time, for reason of fraud, if the city has been notified in writing by a licensed physician that such suspension would endanger the health of the residential customer or any member of the customer's household without giving 48-hour notice excluding weekends and holidays. The 48-hour notice is given by a Lakeland Electric employee either by an in-person contact or a door hanger if the customer is not available. The 48-hour notice will be given on all qualified Medically Essential Service Program accounts to include payment arrangements, NSF cutoffs and delinquent cutoffs. The program does not exempt customers from service disconnection for non-payment of utility bills.

In the event of emergency power failures due to natural causes or unforeseen system problems, the program cannot provide prior notification. In these situations, it is the customer's responsibility to have a power back-up system for their medical equipment, as well as an action plan for proceeding to the nearest medical facility.

During situations beyond the department's control, such as thunderstorms, tornadoes, hurricanes, vehicular accidents, or equipment failures, the customer's electric and/or water service will be restored when the crews are available. No guarantee as to service restoration can be made when the service interruption is beyond the control of the utility.

An annual review is performed for all those listed in the program and a Medically Essential Service Program 12-month review letter is sent to the customer 60 days before the date that the re-certification is due. A brochure is sent along with the letter for re-certification from physician. If a customer does not re-certify by the date of their yearly anniversary or their physician does not validate their medical condition and/or equipment to be enrolled in the program, a Medically Essential Service Program Removal letter is sent via certified mail to advise them that they have been removed from the program.



CUSTOMER'S NAME
1234 ANYWHERE DR
LAKELAND FL 33810 US
Account # 0000000

Sample Bill

Due Date	Amount Due
10/10/2023	\$204.77

Bill Summary

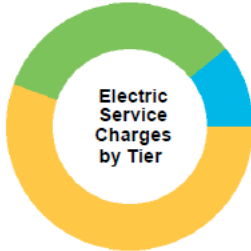

1000 kWh @ 0.05241	\$52.41
500 kWh @ 0.05987	\$29.93
100 kWh @ 0.06622	\$6.63

For a more detailed explanation of rates and charges, please see reverse side.

Billing Date: 09/12/2023	
Previous Bill	\$172.95
Payments/Credits/Returns since 07/10/2023	\$-177.00
Balance Forward	\$-4.05
Penalty Charges	\$3.50
Electric Service Charges	\$205.32
Total Current Charges	\$208.82
Total Amount Due by 10/10/2023	\$204.77

Billing details located on following page(s) ▶

PAY YOUR LAKELAND ELECTRIC UTILITY BILL WITH CASH AT PARTICIPATING STORES

Bring this barcode with you to make a payment. Payments are recognized immediately and posted next business day.

Retailer Instructions:

1. **SCAN** the customer's barcode.
2. The register will **PROMPT** you to enter an amount.
3. **ENTER** the amount the customer wants to pay.
4. **COLLECT** the desired cash amount (and fee, if applicable).
5. When the transaction is **COMPLETE** hand customer the receipt.

799366423610006371683597557884

By accepting or using this barcode to make a payment, you agree to the full terms and conditions available at van.direct.com/pay/terms. After successful payment using this barcode, you may retrieve your full detailed e-receipt at van.direct.com/pay/receipt.

Message Center

Please return this stub along with your payment and note the account number on your check or money order to ensure proper credit to your account.



Account #
0000000

Due Date	Amount Due
DO NOT PAY	\$204.77
Bank Draft Amount	\$31.82
Bank Draft Date	10/09/2023

CUSTOMER'S NAME
1234 ANYWHERE DR
LAKELAND FL 33810 US



(Continued on Sheet No. 9.7.1)

Issued by: Cynthia Clemmons
Manager of Legislative and Regulatory Relations

Effective Date: April 1, 2023

(Continued from Sheet No. 9.7)



CUSTOMER'S NAME
 1234 ANYWHERE DR
 LAKELAND FL 33810 US
Account # 0000000

Bill Detail

Electric Service

Meter Number	No. of Days	Unit of Measure	Current Month	Previous Month	Last Year
430392	32	kWh	1600	1256	1199

The amount due will be drafted at your bank on 10/09/2023
 All balances are subject to penalty if paid after the due date, please see summary of all charges on Page 1 of your bill.

Meter Reading Dates: 07/09/2023 to 08/10/2023

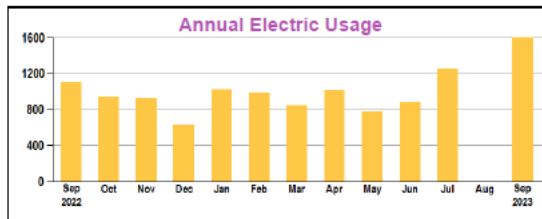

Electric Residential Customer Charge	\$13.50
Electric 1000 KWH @ 0.05241	\$52.41
Electric 500 KWH @ 0.05987	\$29.93
Electric 100 KWH @ 0.06622	\$6.63
Environmental Charge 1600 KWH @ 0.0015907	\$2.55
Fuel Charge 1600 KWH @ 0.045	\$72.00
Polk County Public Service Tax	\$12.28
Lakeland Utility Surcharge	\$11.16
Florida Gross Receipts Tax	\$4.83
Florida Regulatory Commission Surcharge	\$0.03
Current Electric Service Charges	\$205.32

Other Services

Penalty Charge	\$3.50
Other Services and Account Charges	\$3.50

LB2023091212370100_2.xml#4-000000001

The City of Lakeland collects social security numbers for the following purposes: account classification; customer identification; verification; billing; payment; creditworthiness; and any lawful purposes in the conduct of City of Lakeland business.

Address Change

There are several ways to change your mailing address!

- Visit lakelandelectric.com/MyAccount
- Email us at customerservice@lakelandelectric.com
- Call us at 863-834-9535

Our call center hours are, Monday - Friday from 7:30 a.m. to 6:00 p.m.

Contact

- Electric / Water Billing Inquiries..... 863-834-9535
- Wastewater / Solid Waste Billing..... 863-834-8276
- Fallen Power Lines / Water Outages..... 863-834-4248
- False Alarms (Lakeland Police Dept)..... 863-834-6936
- Miscellaneous Fire Dept Billings..... 863-834-8201
- 24-Hour Power Outage Reporting..... 866-834-4248
- 24-Hour Payment Hotline..... 863-834-9535
- TDD (For Hearing Impaired)..... 863-834-8333
- Recycling..... 863-834-8774
- Surge Protection..... 863-834-1500

Bill with Past Due Notice



OVERDUE / LATE SAMPLE BILL
 CUSTOMER'S NAME
 1234 ANYWHERE WY
 LAKELAND FL 33810 US
 Account # 0000000

Page 1 of 2

Due Date	Amount Due
10/10/2023	\$650.23

Bill Summary

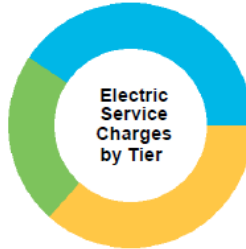

1000 kWh @ 0.05241	\$52.41
500 kWh @ 0.05987	\$29.93
891 kWh @ 0.06622	\$59.00

For a more detailed explanation of rates and charges, please see reverse side.

Billing Date: 09/12/2023	
Previous Bill	\$341.32
Payments/Credits>Returns since 07/24/2023	\$0.00
Balance Forward	\$341.32
Electric Service Charges	\$308.91
Total Current Charges	\$308.91
Total Amount Due by 10/10/2023	\$650.23

Billing details located on following page(s) ▶

PAY YOUR LAKELAND ELECTRIC UTILITY BILL WITH CASH AT PARTICIPATING STORES

Bring this barcode with you to make a payment. Payments are processed immediately and posted next business day.

Retailer Instructions:

1. SCAN the customer's barcode.
2. The register will PROMPT you to enter an amount.
3. ENTER the amount the customer wants to pay.
4. COLLECT the desired cash amount (and fee, if applicable).
5. When the transaction is COMPLETE hand customer the receipt.

799366423610006371683598420868

By accepting or using this barcode to make a payment, you agree to the full terms and conditions available at van.lakelandelectric.com/pay/terms. After successful payment using this barcode, you may retrieve your full detailed e-receipt at van.lakelandelectric.com/pay/receipt.

Available at Service Desk or Money Center

Message Center

00 Please return this stub along with your payment and note the account number on your check or money order to ensure proper credit to your account. LB2023091212370100_2.xml-1-000000002



Account # 0000000

Due Date	Amount Due
10/10/2023	\$650.23

\$

USD Amount Enclosed

CUSTOMER'S NAME
1234 ANYWHERE WY
LAKELAND FL 33810-1922



2

0 000000000065023 000000031583057 0 000000000065023 000000031583057

(Continued on Sheet No. 9.8.1)

Issued by: Cynthia Clemmons
Manager of Legislative and Regulatory Relations

Effective Date: April 1, 2023

(Continued from Sheet No. 9.8)



CUSTOMER'S NAME
1234 ANYWHERE WY
LAKELAND FL 33810 US
Account # 0000000

Bill Detail

Electric Service

Meter Number	No. of Days	Unit of Measure	Current Month	Previous Month	Last Year
537919	32	kWh	2391	2472	1813

Meter Reading Dates: 07/23/2023 to 08/24/2023

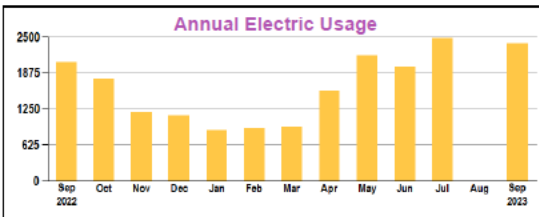

Electric Residential Customer Charge	\$13.50
Electric 1000 KWH @ 0.05241	\$52.41
Electric 500 KWH @ 0.05987	\$29.93
Electric 891 KWH @ 0.06622	\$59.00
Environmental Charge 2391 KWH @ 0.0015907	\$3.80
Fuel Charge 2391 KWH @ 0.045	\$107.59
Polk County Public Service Tax	\$18.53
Lakeland Utility Surcharge	\$16.85
Florida Gross Receipts Tax	\$7.26
Florida Regulatory Commission Surcharge	\$0.04
Current Electric Service Charges	\$308.91

All balances are subject to penalty if paid after the due date, please see summary of all charges on Page 1 of your bill.

Running a business isn't easy, but choosing the right price plan can be. It only takes minutes with our price plan comparison tool.

TRY IT NOW AT

LAKELANDELECTRIC.COM/ENERGYTOOLSET

The City of Lakeland collects social security numbers for the following purposes: account classification; customer identification; verification; billing; payment; creditworthiness; and any lawful purposes in the conduct of City of Lakeland business.

Address Change

There are several ways to change your mailing address!

- Visit lakelandelectric.com/MyAccount
- Email us at customerservice@lakelandelectric.com
- Call us at 863-834-9535

Our call center hours are, Monday - Friday from 7:30 a.m. to 6:00 p.m.

Contact

- Electric / Water Billing Inquiries..... 863-834-9535
- Wastewater / Solid Waste Billing..... 863-834-8276
- Fallen Power Lines / Water Outages..... 863-834-4248
- False Alarms (Lakeland Police Dept)..... 863-834-6936
- Miscellaneous Fire Dept Billings..... 863-834-8201
- 24-Hour Power Outage Reporting..... 866-834-4248
- 24-Hour Payment Hotline..... 863-834-9535
- TDD (For Hearing Impaired)..... 863-834-8333
- Recycling..... 863-834-8774
- Surge Protection..... 863-834-1500

**INTERRUPTIBLE ELECTRIC SERVICE AGREEMENT
FOR GENERAL SERVICE LARGE DEMAND (GSLD) CUSTOMERS**

This Agreement, made and entered into this ____ day of _____, 20____, by and between **Lakeland Electric**, and _____ (hereinafter referred to as "Customer").

WHEREAS, Lakeland Electric wishes to defer building future electric generation by increasing non-firm load, decreasing or delaying increases in firm load, and reducing electric power demand by means of interrupting appropriate electric loads. Said interrupting to occur during periods of capacity shortage; and,

WHEREAS, Customer is a General Service Large Demand (GSLD) classified or eligible customer of Lakeland Electric and desires to reduce its overall cost of electric service, namely through reduction of its demand charges, and, in an effort to achieve such cost reduction, is willing to have its electric service interrupted in the amount of no less than _____ kW of demand; and,

WHEREAS, Customer hereby represents its electric service requirements and use thereof, are such as to be appropriate for interrupting, and further does hereby agree to indemnify and hold harmless Lakeland Electric and the City of Lakeland from and against any and all claims, suits, actions, demands, damages, losses and expenses, direct, indirect, or consequential, arising out of or resulting from any loss of energy by Customer as a result of city exercising its right to interrupt under the terms of this Agreement. Customer agrees that Lakeland Electric and the City of Lakeland will not be held liable for any damages or injuries which may occur as a result of an interruption, announced or un-announced, of Customer electric service pursuant to the applicable Interruptible Rate Schedule.

NOW THEREFORE, by their signature below, Customer does hereby represent that its officers or agents have read and agree to the terms and conditions as set forth in the applicable Interruptible Rate Schedule, a copy of which is attached as Exhibit "A", and Lakeland Electric agrees to provide electric service under said Interruptible Rate Schedule, except for the following:

1. For economic reasons, Lakeland Electric is instructed to use its best efforts and interrupt Customer should the cost of energy from sources other than Lakeland Electric be expected to exceed \$\$\$ cents per kWh. Lakeland Electric does not assume any obligation to purchase energy for the sole purpose of avoiding what is otherwise cause for interruption of service per Rate Schedule IS.
2. Section 10 of the Terms and Conditions of the referenced Interruptible Rate Schedule are amended to authorize Lakeland Electric to exercise reasonable effort to purchase power and energy from other sources for the Customer's use during periods when interruptions are otherwise required.

IN WITNESS WHEREOF, the parties hereto have caused this Agreement to be executed by their duly authorized officers, as of the ____ day of _____, 20____.

CUSTOMER

By: _____

(Print Name)

Title: _____

Lakeland Electric

By: _____

(Print Name)

Title: _____

(Continued from Sheet No. 10)

Contract for Outdoor Lighting

(Continued from page 1)

Terms and Conditions (continued from page 1)

- The City shall repair any burn out or defect in the lamps or equipment within five (5) business days after notification by the Customer. It is the Customer's sole responsibility for reporting any burn out or defects in the lamps provided hereunder. This period may be exceeded during times of utility emergency or extenuating circumstances.
- Fixtures, lamps, or equipment damaged as a result of the Customer's misuse or abuse, while in use under this Contract, will be replaced or repaired by the City and the cost thereof will be paid by the Customer.
- The Customer shall assume any and all responsibility for the location of the light. If the location of a light generates a complaint from one of the Customer's neighbors, it will be the responsibility of the Customer to resolve that complaint. The City will make a reasonable effort to assist the Customer by re-aiming the fixture, within the initial 30 day period. After the initial 30 day period, the Customer will be financially responsible for any change or adjustments. If a resolution of the complaint can not be reached, it will be the Customer's choice of course of action.
- This Contract shall be for an initial term of five (5) years with the installation of decorative style of lights, and three (3) years for all other light styles. The Contract shall begin at the commencement of service and shall continue thereafter until terminated by either party with thirty (30) days written notice. During the initial term, the Customer may terminate this Contract by providing written notice and payment to the City of a lump sum charge, to cover the remainder of the initial term of service, less the energy and fuel charges. Should the Customer move or discontinue electric service for any reason during the initial term, the total remaining amount under the initial term shall become due and payable in a lump sum. In the event any payment becomes past due, the City shall be relieved of any obligations set forth in this Contract, and will terminate electric service to said lighting system.
- For a terminated Contract, the City may deduct any past due amounts from any deposits the Customer may have with the City for any other accounts. Further, the City may assess a Late Charge in the amount of \$3.50 per month or 1.5% of the total balance owed, whichever is greater.
- If the Customer desires the relocation of a light, a relocation charge will be made for the amount of actual time and material involved.
- If a Customer requests for a light to be installed on the same property, and for same general usage (as determined by the City), within one (1) year of a previous light removal, there will be an installation charge for this new installation.
- This Contract may be assigned by either party if written consent is received from the other party.
- This Contract is made under and complies with the terms and conditions of the City's Tariff Schedule OL – Private Area Lighting (which is hereby incorporated herein by reference and made a part hereof) and is subject to any changes under Schedule OL approved by the City Commission.
- The City reserves the right to modify requirements of this Contract at anytime to comply with Changes in Schedule OL once the affected parties have been notified.

FACILITIES CHARGE AGREEMENT

THIS Agreement is made and entered into this ____ day of ____, 20__ (the “Effective Date”), between the City of Lakeland, a Florida municipal corporation, (the “City”) and _____ (the “Customer“).

WITNESSETH:

WHEREAS, the Customer has requested extraordinary electric facilities to service its needs; and

WHEREAS, the City is willing to provide the requested facilities upon the terms and conditions set forth below.

NOW, THEREFORE, for mutual consideration, the sufficiency of which is hereby acknowledged, the parties hereby agree as follows:

1. **TERM.** The term of this agreement shall be ten (10) years from the date first set above.
2. **PROVISION OF ELECTRIC FACILITIES.** The City agrees to furnish, install, and maintain the electric facilities described on Exhibit “A” at the Customer’s facility located at: _____ (the “Electric Facilities”). The Customer will be required to pay a facilities charge each billing period based upon the actual cost of the Electric Facilities provided hereunder which shall be in addition to the standard charges for the electrical services provided by the City (the “Facilities Charge”). In the event of a change in ownership or the Customer ceases receiving electrical service at the Customer’s location, the Facilities Charge shall be binding on Customers successors in interest at the service location.
3. **MAINTENANCE, REPAIR, AND REPLACEMENT.** The Electric Facilities provided for the benefit of the Customer shall be owned and maintained by the City and shall at all times be subject to its inspection, repair, or replacement. The City’s liability to replace a particular item of equipment during the term of this Agreement is limited in total to two (2) times the original cost of the item. The Customer shall be responsible for any amounts exceeding this amount. The City shall have no responsibility for the maintenance, repair, or replacement of Customer owned facilities. All switches or other equipment with the capability of connecting two or more of the City’s circuits together shall be under the sole control of the City.
4. **SECURITY AND EARLY TERMINATION CHARGES.** Within thirty (30) days of installation of the Electric Facilities, the Customer shall increase its cash deposit, bond, or irrevocable letter of credit currently held by the City as security for the Customers electric service by an amount equal to two (2) months of the Facilities Charge. In the event the Customer terminates this agreement for any reason, or the City terminates this Agreement due to a default by the Customer, the Customer shall be liable for early termination fees as follows:
 - a. Years 1-5 = (Facilities Charge X 60) – Facilities Charge paid as of date of termination*
 - b. Years 6-10 Facilities Charge X 3

* The early termination fee for year five will be the greater of a. or b.

5. **VENUE.** This Agreement shall be interpreted, construed, governed, and enforced in accordance with the laws of the State of Florida, without regard to such state’s choice of law provisions, if any, which may dictate that the law of another jurisdiction shall apply. Venue of any court proceeding arising out of or resulting from this Agreement shall be in Polk County, Florida, or the United States District Court in and for the Middle District of Florida, Tampa, Division.

(Continued on Sheet No. 11.0.1)

(Continued from Sheet No. 11)

6. **ASSIGNMENT.** Customer shall not assign this Agreement, or any rights hereunder without the prior, written consent of the City. The City shall have no obligation to provide said consent.

7. **DEFAULT.** If, during the term of this Agreement, Customer shall be in default of any of the material terms or conditions of this Agreement, file for bankruptcy protection, or make a general assignment for the benefit of creditors, the City may immediately pursue the security provided hereunder and suspend its performance until such delinquency or default has been corrected. If the Customer fails to correct such delinquency or default within thirty (30) days of notice by the City, the City may terminate this Agreement and seek such the termination fees set forth in paragraph 4 above.

8. **TERMINATION.** Notwithstanding any other provision of this Agreement, the City may, upon thirty (30) days prior written notice to Customer, terminate this Agreement for its convenience, without liability to the Customer.

9. **FORCE MAJEURE.** Neither party shall be considered in default on the performance of its obligations herein to the extent that performance of such obligations or any of them is delayed or prevented by force majeure. Force majeure shall include, without limitation, hostilities, revolution, civil commotion, strikes, epidemic, accident, fire, flood, wind, earthquake, explosion, blockage, or any law, proclamation, regulation, or ordinance, demand, or requirement of any government or governmental agency having or claiming to have jurisdiction over the work, or, with respect to materials purchased for the work, or over the parties hereto or other act of government or any act of God or any cause whether of the same or different nature, existing or future; provided that the cause, whether or not enumerated in this provision, is beyond the control and without the fault or negligence of the party seeking relief under this provision.

10. **PAYMENT.** Net bills are due when rendered and are delinquent thirty (30) days after the billing date.

11. **TERMS AND CONDITIONS.**

- a. Upon reasonable advance notice, Customer shall allow the City access and entry to Customer's property and premises during normal business hours (or at any hour in the case of a power outage or similar emergency) for the purpose making inspections of and repairs to the City's property.
- b. The paragraph headings appearing in this Agreement are for convenience only and shall not affect the meaning or interpretation of the Agreement.
- c. The waiver by either Party of any default by the other Party hereunder, or the failure of either Party to, at any time, require strict compliance with any of the terms and conditions of this Agreement, shall not be deemed a waiver by such Party of any default of the other or a waiver by any such Party of its right to strict compliance by the other Party.
- d. Except as may be otherwise expressly provided, remedies provided under this Agreement shall be cumulative and in addition to any other remedies provided at law or equity.
- e. If any provision of this Agreement is found contrary to law or unenforceable by any court, the remaining provisions shall be severable and enforceable in accordance with their terms, unless such unlawful or unenforceable provision is material to the transactions contemplated, hereby, in which case the parties shall negotiate in good faith a substitute provision.

(Continued on Sheet No. 11.0.2)

(Continued from Sheet No. 11.0.1)

- f. This Agreement only relates to the provision of Electric Facilities identified herein. Any other requirements, rules, or City practices, pertaining to providing services or facilities shall not be changed by this Agreement without express written agreement between the parties.
- g. In the event it becomes necessary for the City to bring an action to collect any amounts due under this Agreement, the Customer shall be liable for all court costs and attorney's fees incurred by the City.

12. LIMITATION OF LIABILITY. IN NO EVENT WILL THE CITY HAVE ANY LIABILITY TO THE CUSTOMER FOR ANY INCIDENTAL, SPECIAL, STATUTORY, INDIRECT OR CONSEQUENTIAL DAMAGES, OR FOR ANY LOSS OF PROFITS, OVERHEAD, PRODUCT, OR REVENUE. THE CITY'S AGGREGATE LIABILITY ARISING OUT OF OR RESULTING FROM THIS CONTRACT WILL NOT EXCEED THE ACTUAL COST OF THE ELECTRIC FACILITIES MULTIPLIED BY A FACTOR OF TWO (2). THIS LIMITATION OF LIABILITY WILL APPLY TO ANY DAMAGES, HOWEVER CAUSED, AND ON ANY THEORY OF LIABILITY, WHETHER FOR BREACH OF CONTRACT, TORT (INCLUDING WITHOUT LIMITATION NEGLIGENCE), DELAY, OR OTHERWISE, REGARDLESS OF WHETHER THE LIMITED REMEDIES AVAILABLE TO THE CUSTOMER FAIL FOR THEIR ESSENTIAL PURPOSE.

IN WITNESS WHEREOF, the parties have caused this Agreement to be executed as of the date first above written.

FOR CUSTOMER

FOR THE CITY OF LAKELAND

By: _____

By: _____

Title: _____

Title: _____

CUSTOMER PARTICIPATION IN RENEWABLE ENERGY PROGRAM

Lakeland Electric Provided Photovoltaic Energy Generation:

1. Lakeland Electric, under terms of its purchase power agreement with third parties, may cause to be installed at Customer's facilities photovoltaic (PV) equipment for the purpose of generating electricity. Commercial and Industrial Customers are eligible to participate so long as a) electric service is provided by Lakeland Electric and b) the Customer's facilities meet the site requirements.
2. Participation by the Customer is voluntary. Customer shall sign the appropriate agreement(s) to host the PV generating facilities.
3. Throughout the life of the agreement(s) in #2 above, and in lieu of other payments to the Customer for use of Customer's premise, Lakeland Electric shall pay Customer a Participation Rebate.
4. Participation Rebate shall be at the rate of \$.02 per kWh of PV energy generated in association with Customer's premise.
5. Lakeland Electric shall provide necessary meters.
6. Participation Rebate shall be paid monthly, and payment is usually credited against the Customer's bill for electric service.

Lakeland Electric Provided Solar Hot Water:

1. Lakeland Electric, under contract terms with third parties, offers its customers solar hot water. Residential Customers are eligible to participate so long as a) electric service is provided by Lakeland Electric and b) the Customer's facilities meet the site requirements.
2. Participation by the Customer is voluntary. Customers shall sign the appropriate agreement(s) for the installation of equipment.
3. Solar Hot Water Customers will be billed a monthly energy charge of \$34.95 along with the bill for electric service under all other applicable rate schedules.
4. Participation is limited to existing Customers in the Program as of the effective date of this tariff.

**SURGE PROTECTION PROGRAM
METER SOCKET SURGE ARRESTOR LEASE AGREEMENT**

THIS AGREEMENT made and entered into this _____ day of _____, 20____ by and between _____ whose billing address is _____, hereinafter called Customer (“Customer”), and the City of Lakeland, Lakeland Electric, hereinafter called (“Lakeland Electric”).

WITNESSETH:

That, for and in consideration of the terms and conditions herein specified, the parties hereby agree as follows:

1. Lakeland Electric shall supply and install a Meter Socket Surge Arrestor (“MSA”), at the following location:
_____.
2. The installation charge for the MSA is \$34.95 plus tax, and the monthly payment shall be \$5.61 plus tax for a minimum term of 24 months (“Initial Term”). The monthly payment shall be prorated for a partial month of service. Billing will be included in the Customer’s regular monthly bill for electricity, and payment shall be due and payable in accordance with the terms and conditions of the electric rate schedule applicable to said Customer. If Customer becomes past due on any bill rendered by Lakeland Electric, Lakeland Electric is hereby authorized to take necessary action, as provided in Paragraph 4 below, to protect its interest. If Customer desires to cancel this Agreement prior to the expiration, Customer may do so by paying Lakeland Electric the remaining fees due, or a fifty dollar (\$50) cancellation fee, whichever is less. At the end of the Initial Term, this agreement shall remain in effect from month to month until cancelled in writing by either party. After the Initial Term no cancellation fee shall apply. Upon cancellation, Lakeland Electric shall remove the MSA from the meter at no cost to Customer.
3. Lakeland Electric shall have continuous access to the MSA, which is installed at the meter. Although Lakeland Electric has general responsibility for maintaining and servicing the MSA, Customer shall be responsible for damage to the MSA caused by tampering or vandalism.
4. The MSA shall at all times remain the property of Lakeland Electric. Customer acknowledges Lakeland Electric’s ownership rights, and hereby authorizes Lakeland Electric to withhold any funds on deposit with the City of Lakeland for electric or water service to secure payment of the amounts due hereunder in the event of any default or termination by Customer, including termination of its electric or water service which is provided by the City of Lakeland.
5. **CUSTOMER ACKNOWLEDGES THAT LAKELAND ELECTRIC MAKES NO WARRANTY EXPRESS OR IMPLIED, INCLUDING ANY WARRANTY OF MERCHANTABILITY OR FITNESS FOR A PARTICULAR PURPOSE. THE ONLY WARRANTY AVAILABLE IS ANY WARRANTY THE EQUIPMENT MANUFACTURER MAY OFFER.**
6. This Agreement shall be governed and constructed in accordance with the laws of the State of Florida.

IN WITNESS WHEREOF, the parties hereto have caused this Agreement to be executed as of the date and year first written above.

Customer

City of Lakeland Electric

By: _____

By: _____

Account No: _____

SERVICE AGREEMENT FOR ECONOMIC DEVELOPMENT RIDER

- New Establishment
- Existing Establishment with an Expanded Load

Customer Name

Address

Type of Business

The customer hereto agrees as follows:

1. To create _____ full-time jobs.
2. That the quantity of new or expanded load shall be _____ KW of Demand.
3. The nature of this new or expanded load is _____.
4. To initiate service under this Rider on _____ and terminate service under this Rider on _____. This shall constitute a period of five (5) years.
5. In case of early termination, the customer must pay Lakeland Electric the difference between the otherwise applicable rate and the payments made, up to that point in time, plus interest.
6. To provide verification that the availability of this Rider is a significant factor in the customer's location/expansion decision.
7. If a change in ownership occurs after the customer contracts for service under this Rider, the successor customer may be allowed to fulfill the balance of the contract under Rider EDIR and continue the schedule of credits.

Signed: _____

Accepted by: _____

Lakeland Electric

Title: _____

Date: _____

Date: _____

Issued by: Cynthia Clemmons
Manager of Legislative and Regulatory Relations

Effective Date: October 1, 2023