



Agreement for parallel connection of a Photovoltaic Generator and/or an Energy Storage System (PV-ESS) up to 2MW with the City of Lakeland's Electric Distribution System

This Agreement is made and entered into this ____ day of _____, 20____, by and between, the City of Lakeland, Florida on behalf of its municipal utility, Lakeland Electric ("LE") and _____ (the "Customer"), whose address is _____ (the "Property").

Whereas, LE endeavors to encourage the development of electric power generation using renewable fuels; and

Whereas, the Customer desires to construct and/or operate a PV-ESS connected in parallel with LE's power distribution system (hereafter "Grid") through the Customer's connection to the meter at or on the Property; and

Whereas, there are electrical safety, power quality, and other issues with such an installation.

Now, therefore, for and in consideration of the mutual covenants and agreements the parties hereby agree as follows:

1. Notify LE immediately if PV-ESS system is greater than 10kW.
2. The PV-ESS can only be connected in parallel with the LE distribution system once the following conditions are met:
 - a. The Customer provides written documentation that it has had a Final Electrical Inspection from the City/County.
 - b. The Customer and LE have signed this Agreement.
 - c. The installation is in compliance with all provisions in the attached Appendix A, hereby made a part of this Agreement.
 - d. Appendix B, attached hereto this Agreement is completed and signed by the parties identified in the application.
 - e. Appendix C, attached hereto has been signed by the Customer and notarized.
3. This Agreement applies solely to Customer's PV-ESS at or on the Property.

4. **LE's Inspection and Approval.** Prior to operation, LE reserves the right to inspect the PV-ESS installation to ensure compliance with the standards and codes noted in Appendix A. Upon inspection, if the system is in compliance, LE will provide written approval of the interconnection in accordance with Appendix B within ten (10) business days following the request for inspection and approval.

It may be necessary for LE to take, or request from the Customer, photographs of the Customer's PV-ESS system during the inspection.

Parallel operation of a PV-ESS with the Grid **shall not** begin without LE's final written approval.

5. For Tiers 2 & 3, as defined in Appendix A, LE may require an Interconnection Study and require the Customer to pay an Interconnection Study Charge. If an Interconnection Study is necessary, further design review, testing and additional equipment as identified in the study may be required at the Customers' sole expense prior to LE approval.

In no case shall the total size of all PV-ESS exceed 100% of the Customer's annual consumption. If the total size of the PV-ESS exceeds 90% of the capacity of the transformer bank or service cables serving the Property and/or if additional equipment is required, this will be at the Customer's sole expense.

6. All Customers installing PV-ESS systems are advised to schedule a PV Audit for their home before submitting an application to LE.

7. **Extreme Conditions.** LE reserves the right to refuse to accept electric power from the PV-ESS system under extreme conditions as described below. If LE chooses to exercise this option, which may involve physically disconnecting the Grid from the Customer's PV-ESS, it agrees to make reasonable efforts to notify the Customer when such conditions exist or are anticipated to exist, and to reconnect when the adverse conditions no longer exist. Examples of conditions that may lead to disconnection include, but may not be limited to:

- a. LE System emergencies and/or maintenance requirements;
- b. Hazardous conditions existing on the PV-ESS or its protective equipment;
- c. Adverse effects of the PV-ESS system's operation on LE's Grid, or on other LE customers; or
- d. Failure of the PV-ESS to comply with regulations, rules, orders or decisions of any government or regulatory authority having jurisdiction over LE, generating equipment or operation.

8. If the kWh delivered to LE's Grid exceeds the kWh delivered to the Customer's home in a billing cycle, a credit for the net kWh delivered to LE's Grid shall be carried forward to the next billing cycle. In no event shall the Customer be paid for excess energy delivered to LE's Grid. See [Appendix D](#) for additional information regarding pricing and rates.

9. PV-ESS Customers shall retain any Renewable Energy Certificates associated with the electricity produced by their customer-owned renewable generation equipment. Any additional meters necessary for measuring the total renewable electricity generated for the purpose of receiving Renewable Energy Certificates shall be installed at the Customer's sole expense.
10. LE reserves the right to terminate this Agreement with or without cause with thirty (30) calendar days' written notice.
11. Any material default of this Agreement by the Customer shall allow LE to immediately terminate this Agreement and disconnect the Customer's PV-ESS system from LE's Grid.
12. The Customer agrees to immediately notify LE, in writing, if any of the following occur to Customer:
 - a. Sells the Property;
 - b. Makes a change to the PV-ESS system;
 - c. Relocates the PV system as it requires LE's re-approval of the system, which in turn may require updated Engineer Drawings;
 - d. Sells/removes the PV-ESS system or a portion thereof; or
 - e. Performs maintenance on the PV-ESS system that may have an impact on the LE's Grid.

Change notice should be directed to:

LE Solar Team
 Lakeland Electric Mail Code: LE- ED ENG
 501 East Lemon Street
 Lakeland, FL 33801
 Phone: (863) 834 - 4647
 solar@lakelandelectric.com

Insurance and Indemnification. The Customer shall provide proof of and maintain at all times a general liability insurance policy for personal and property damage in the amount of at least \$100,000. A standard homeowner's policy in at least this amount may meet this requirement. In addition, Customer shall properly execute the Indemnification Agreement in the exact form as attached as Appendix B and deliver it to LE upon submitting the Application set forth below.

By _____ Date: _____
 Customer

By _____ Date: _____
 City

APPENDIX A

INTERCONNECTION REQUIREMENTS FOR PHOTOVOLTAIC SYSTEMS LESS THAN OR EQUAL TO 2MW

A. Standards and Codes

System Installation. The installed system must be in compliance with: a) *IEEE 1547-2003, Standard for Interconnecting Distributed Resources with Electric Power Systems* and b) all relevant articles of the *1999 National Electrical Code* (or subsequent revisions).

Inverter(s). Defined in Appendix A, the inverter(s) must be listed and in compliance with Underwriters Laboratories (UL) Subject 1741, Standard for Static Inverters and Charge Controllers for Use in Photovoltaic Systems. Utility-interactive inverters that pass the tests of the new UL 1741 standard will be, by definition, “non-islanding” inverters and will comply with all elements of the IEEE 1547-2003 interconnection standard. The 1999 National Electrical Code requires that all utility-interactive photovoltaic systems use listed inverters that pass UL 1741.

PV Modules and Panels. PV modules and panels must be listed and be in compliance with UL Standard 1703, Standard for Safety: Flat-Plate Photovoltaic Modules and Panels. PV modules must be in compliance with *IEEE Standard 1262-1995, IEEE Recommended Practice for Qualification of Photovoltaic (PV) Modules* (or, equivalently, IEC 61215).

Energy Storage System (ESS). ESS must be listed and be in compliance with UL Standard 1642, Standard for Lithium Batteries and Standard for Energy Storage Systems and Equipment.

External Disconnect Switch. LE requires a manual, lockable, load break utility-interface disconnect switch between the output of the photovoltaic inverter and any additional Customer owned energy sources, and the Customer’s wiring connected to LE’s Grid. The load break device shall be visible, accessible to Lakeland’s employees and, adjacent to existing utility meter. Customer hereby grants a full license to access the Property and the PV-ESS to ensure compliance herewith.

Metering Arrangements. The PV-ESS Inverter output must be connected, by the Customer, to the Customer side of the normal service meter through an External Disconnect Switch.

- a. The normal service meter shall be replaced with a meter that will measure and register power flowing into the Customer’s property and measure and register power flowing from the customer’s resource into the Grid.
- b. Upon completion and final acceptance of the Customer’s PV-ESS installation, LE will install these meters on the first day of the following billing cycle.

Testing of Protective Relays. LE reserves the right to test the anti-islanding features and the power output quality of the inverter.

PV System Equipment Protection. It is the responsibility of the Customer to protect its generating equipment, inverters, protection devices, and other system components from damage by the normal conditions and operations that occur on the part of LE in delivering and restoring System power. LE hereby disclaims any liability whatsoever for damage to the Customer's equipment.

B. Definitions

A **Tier 1 Photovoltaic (PV) System** is a solar electric generator with an array rating less than 10 kW under standard operating conditions (SOC) of 1000 watts/m² solar irradiance, nominal operating cell temperature, air mass 1.5, and ASTM standard solar spectrum.

A **Tier 2 Photovoltaic (PV) System** is a solar electric generator with an array rating greater than 10 kW and less than or equal to 100 kW under standard operating conditions (SOC) of 1000 watts/m² solar irradiance, nominal operating cell temperature, air mass 1.5, and ASTM standard solar spectrum.

A **Tier 3 Photovoltaic (PV) System** is a solar electric generator with an array rating greater than 100 kW and less than or equal to 2 MW under standard operating conditions (SOC) of 1000 watts/m² solar irradiance, nominal operating cell temperature, air mass 1.5, and ASTM standard solar spectrum.

An **Inverter**, also referred to as a *power conditioner*, is a dc to ac device that converts PV energy to ac energy for utility interconnection. The inverter contains many control functions, such as voltage and frequency monitoring and protection against islanding. These Interconnection Requirements apply only to static inverters. Rotating devices cannot be used.

**APPENDIX B
APPLICATION AND COMPLIANCE FORM
FOR PV-ESS LESS THAN 2MW**

A. Applicant Information	
_____	_____
Customer Name	Telephone #
_____	_____
Mailing Address	Email
_____, FL _____	
City	ZIP Code
_____	_____
Service address if different from mailing address	City

City account number	

B. Photovoltaic and Energy Storage System Information

PV System Name/Model: _____

PV Array DC Power at SOC in watts _____

PV Array manufacturer and model _____

PV Inverter manufacturer and model _____

PV Array location _____

PV Inverter location _____

ESS Name/Model _____

ESS DC Power at SOC in watt-hours _____

ESS manufacturer and model _____

ESS Inverter manufacturer and model _____

ESS location _____

AC Disconnect Location _____

C. Installation Contractor Information

Installation contractor name FL license #

Contractor address City, State, ZIP

Contractor phone Email

Proposed installation date

D. Hardware and Installation Compliance

1. The system hardware is in compliance with Underwriters Laboratories (UL) *Standard 1741, Standard for Static Inverters and Charge Controllers for Use in Photovoltaic Systems* and *UL 1703, Standard for Safety: Flat-Plate Photovoltaic Modules and Panels*, and *IEEE 1262-1995, IEEE Recommended Practice for Qualification of Photovoltaic (PV) Modules*.
2. The system has been installed in compliance with *IEEE 1547, Standard for Interconnecting Distributed Resources with Electric Power Systems* and the *1999 National Electrical Code (NEC)*.

Contractor signature

Date

Print name

E. Owner Acknowledgment

The system has been installed to my satisfaction and I have been given system warranty information, and an operation manual. Also, I have been instructed in the operation of the system.

Owner signature

Date

F. Utility Approval

PV Installation Satisfies LAKELAND ELECTRIC Interconnection Requirements

LAKELAND ELECTRIC Representative Name (Print):

LAKELAND ELECTRIC Representative Signature:

Date

APPENDIX C
HOLD HARMLESS/INDEMNIFICATION

To the fullest extent permitted by laws and regulations, Customer shall defend, indemnify, and hold harmless the City, its officers, directors, agents, guests, invitees, and employees from and against all claims, damages, losses, and expenses, direct, indirect, or consequential (including but not limited to fees and charges of engineers, architects, attorneys, and other professionals and court and arbitration costs) arising out of or resulting from any acts of commission, omission, negligence, recklessness or intentional wrongful misconduct of the Customer, or any other person or organization directly or indirectly employed by the Customer to perform or furnish any of the work or anyone for whose acts any of them may be liable.

In any and all claims against the City, or any of its officers, directors, agents, or employees by any employee of the Customer, or any other person or organization directly or indirectly employed by the Customer to perform or furnish any of the work or anyone for whose acts any of them may be liable, this indemnification obligation shall not be limited in any way by any limitation on the amount or type of damages, compensation, or benefits payable by or for the Customer or any other person or organization under workers' or workmen's compensation acts, disability benefit acts, or other employee benefit acts, nor shall this indemnification obligation be limited in any way by any limitation on the amount or type of insurance coverage provided by the City, or the Customer.

Applicability: It is the express intent of the Customer that this agreement shall apply for the project indicated below:

Parallel connection of a photovoltaic generator and/or an Energy Storage System (PV-ESS) up to 2MW with the City of Lakeland's Electric Distribution System

Savings Clause: The parties agree that to the extent the written terms of this Indemnification conflict with any provisions of Florida laws or statutes, in particular Sections 725.06 and 725.08 of the Florida Statutes, the written terms of this indemnification shall be deemed by any court of competent jurisdiction to be modified in such a manner as to be in full and complete compliance with all such laws or statutes and to contain such limiting conditions, or limitations of liability, or to not contain any unenforceable, or prohibited term or terms, such that this Indemnification shall be enforceable in accordance with and to the greatest extent permitted by Florida Law.

Name of Organization

BY: _____
Signature of Owner or Officer

ATTEST: _____
Corporate Secretary or Witness

STATE OF: _____

COUNTY OF: _____

The foregoing instrument was acknowledged before me this _____ day of _____, 20__.

by _____, of _____.

Printed Name of Owner / Officer

Address

He/She is personally known to me or has produced _____ as

State Driver's License Number

identification, and did _____ / did not _____ take an oath.

Signature of Person Taking Acknowledgment

Printed Name of Person Taking Acknowledgment

Title

Serial Number, if any

Notary Seal

APPENDIX D

Residential Service Demand Rate (RSD)

Effective January 1, 2016, Lakeland Electric customers who choose to install photovoltaic (PV) solar panels on their home will be assigned to the Residential Service Demand (RSD) price plan¹.

The RSD plan is a combination of two things: 1) a peak demand charge (per kilowatt) that is **only** applied during a defined peak period and 2) a lower energy rate (per kilowatt-hour). Customers on the new RSD plan can benefit by:

- lessening their demand during specified peak periods and
- paying a lower energy rate at all times.

The RSD monthly bill is calculated using the Customer's total kilowatt-hour consumption plus the customer's highest demand during the peak period.

Additional information regarding the RSD price plan is available at Lakeland Electric Customer Service (863-834-9535) or on the Lakeland Electric website.

Go to <https://lakelandelectric.com/Solar#1802297-solar-price-plan> or go to *Customers » Programs & Services » ReEnergize Lakeland » Solar*, on our website.

Commercial Demand Rate (CD)

Effective January 1, 2016, Lakeland Electric Commercial and Industrial customers who choose to install photovoltaic (PV) solar panels on facilities not classified as residential homes will be assigned to one of the Commercial Demand (CD) price plans.¹

Commercial Customers have the potential to see lower electric bills with our Shift-to-Save price plan. With this program, companies receive a reduced rate when using electricity during "off-peak" times when Lakeland Electric's total Customer demand for power is lowest. Rates are based on the maximum amount of electricity your company uses during specific time periods.

A CD monthly bill is calculated using the customer's total kilowatt-hour consumption plus the customer's highest demand during the peak period.

Additional information regarding the CD price plans is available at Lakeland Electric Customer Service (863-834-9535) or on the Lakeland Electric website.

Go to <https://lakelandelectric.com/Customers/Pick-A-Plan/Price-Plans>

Please note that this information updated a regular basis and the pricing plan is subject to change based on Lakeland Electric's tariff which can be found at <https://lakelandelectric.com> under *Customers » Pick a Plan » Pricing Plans* and click on "[Rate Tariffs](#)"

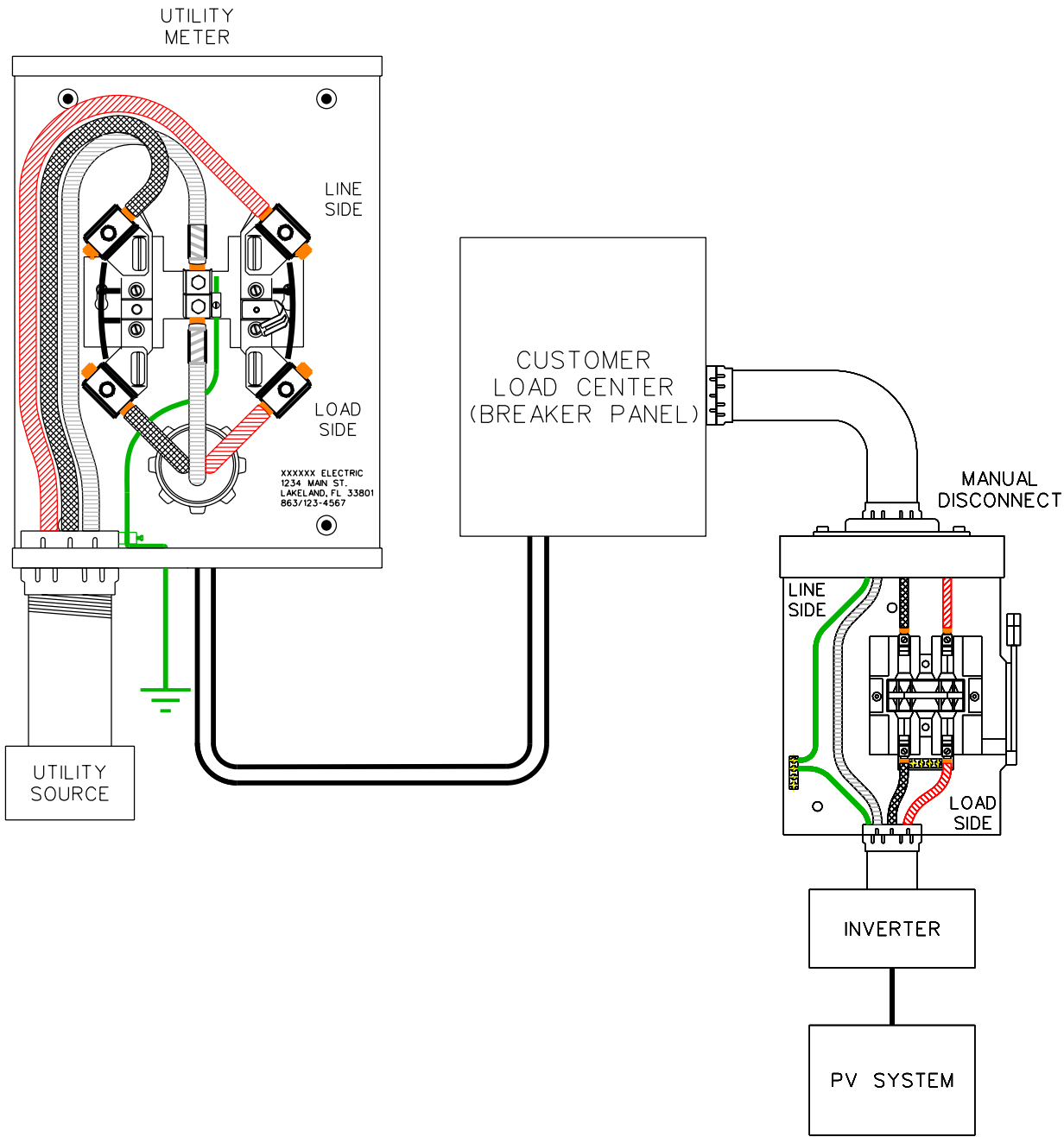

NOTES:

1. UTILITY INTERCONNECT POINT IS ON THE SOLAR METER LOAD SIDE LUG.
2. CUSTOMER CONNECTION FROM THE PV SYSTEM DISCONNECT SWITCH IS ON THE METER LINE SIDE LUG.
3. NEUTRAL CONNECTIONS ARE NOT MADE IN THE SOLAR METER CAN.
4. METER CANS AND DISCONNECT SWITCH BOXES SHALL BE PROPERLY GROUNDED.
5. WHILE ENTRY POINTS MAY DIFFER THAN SHOWN, TERMINATIONS SHALL BE MADE IN THE SPECIFIED LOCATIONS.
6. MANUAL DISCONNECT SWITCHES SHALL BE LOCATED ON THE EXTERIOR OF THE STRUCTURE.
7. SERVICE MUST UTILIZE PROPER CONDUIT, BUSHINGS, AND CONNECTORS.
8. THE UTILITY BILLING METER CAN SHALL NOT BE USED AS A PASSTHROUGH OR HAVE ANY ADDITIONAL CONNECTIONS MADE INSIDE IT.

E60SMSLR01.DGN

JMF 10/25/19
BRS 01/29/19
XXX 99/99/99

METERING

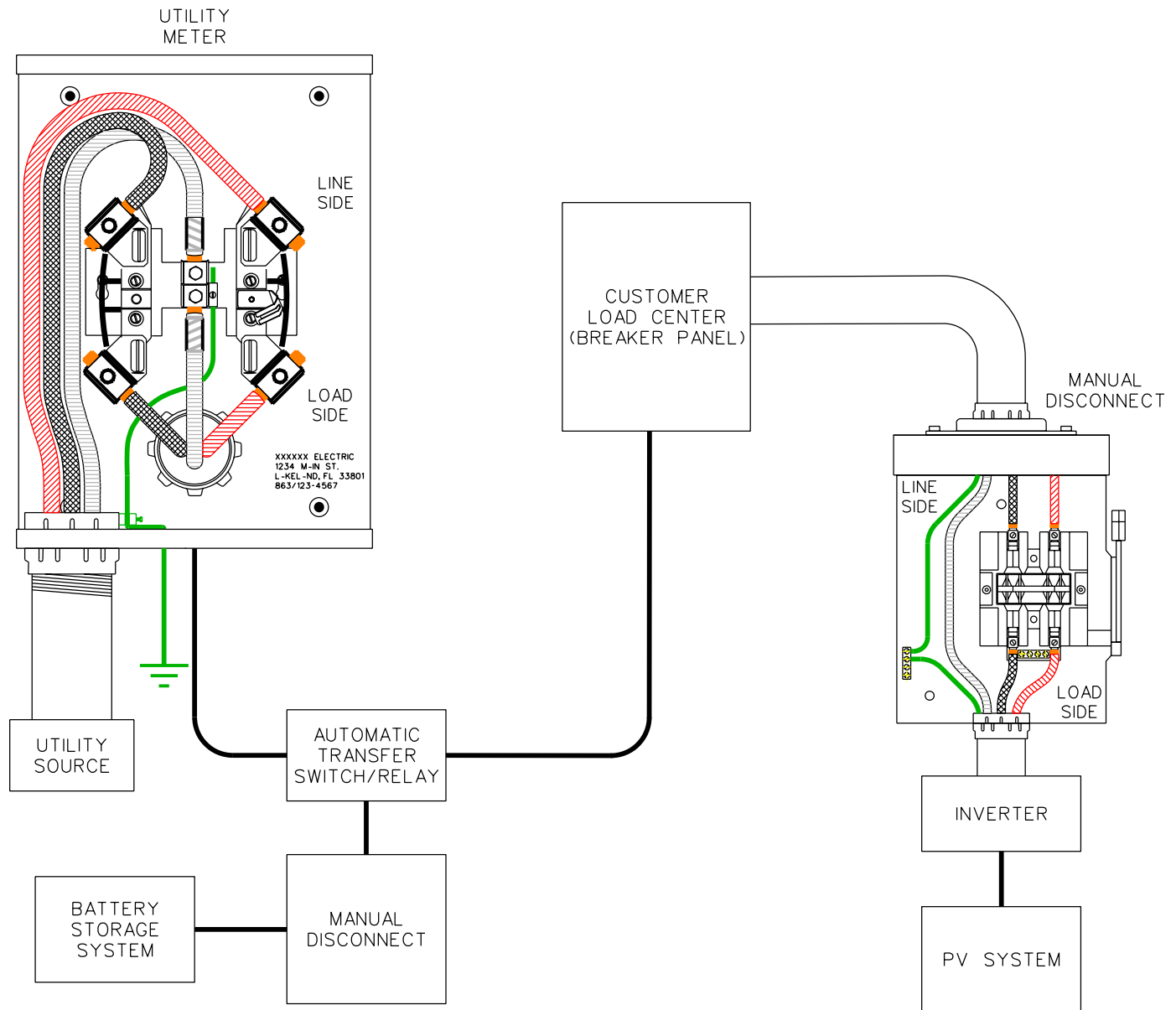

NOTES:

1. CUSTOMER CONNECTION FROM THE PV SYSTEM DISCONNECT SWITCH IS ON THE METER LINE SIDE LUG.
2. NEUTRAL CONNECTIONS ARE NOT MADE IN THE MANUAL DISCONNECT.
3. METER CANS AND DISCONNECT SWITCH BOXES SHALL BE PROPERLY GROUNDED.
4. WHILE ENTRY POINTS MAY DIFFER THAN SHOWN, TERMINATIONS SHALL BE MADE IN THE SPECIFIED LOCATIONS.
5. MANUAL DISCONNECT SWITCHES SHALL BE LOCATED ON THE EXTERIOR OF THE STRUCTURE.
6. SERVICE MUST UTILIZE PROPER CONDUIT, BUSHINGS, AND CONNECTORS.
7. THE UTILITY BILLING METER CAN SHALL NOT BE USED AS A PASSTHROUGH OR HAVE ANY ADDITIONAL CONNECTIONS MADE INSIDE IT.

JMF 10/25/19
BRS 01/29/19
XXX 99/99/99

LAKELAND ELECTRIC
 SOLAR METERING CONFIGURATION
 WITH BATTERY STORAGE
 (ALTERNATE CONFIGURATION)

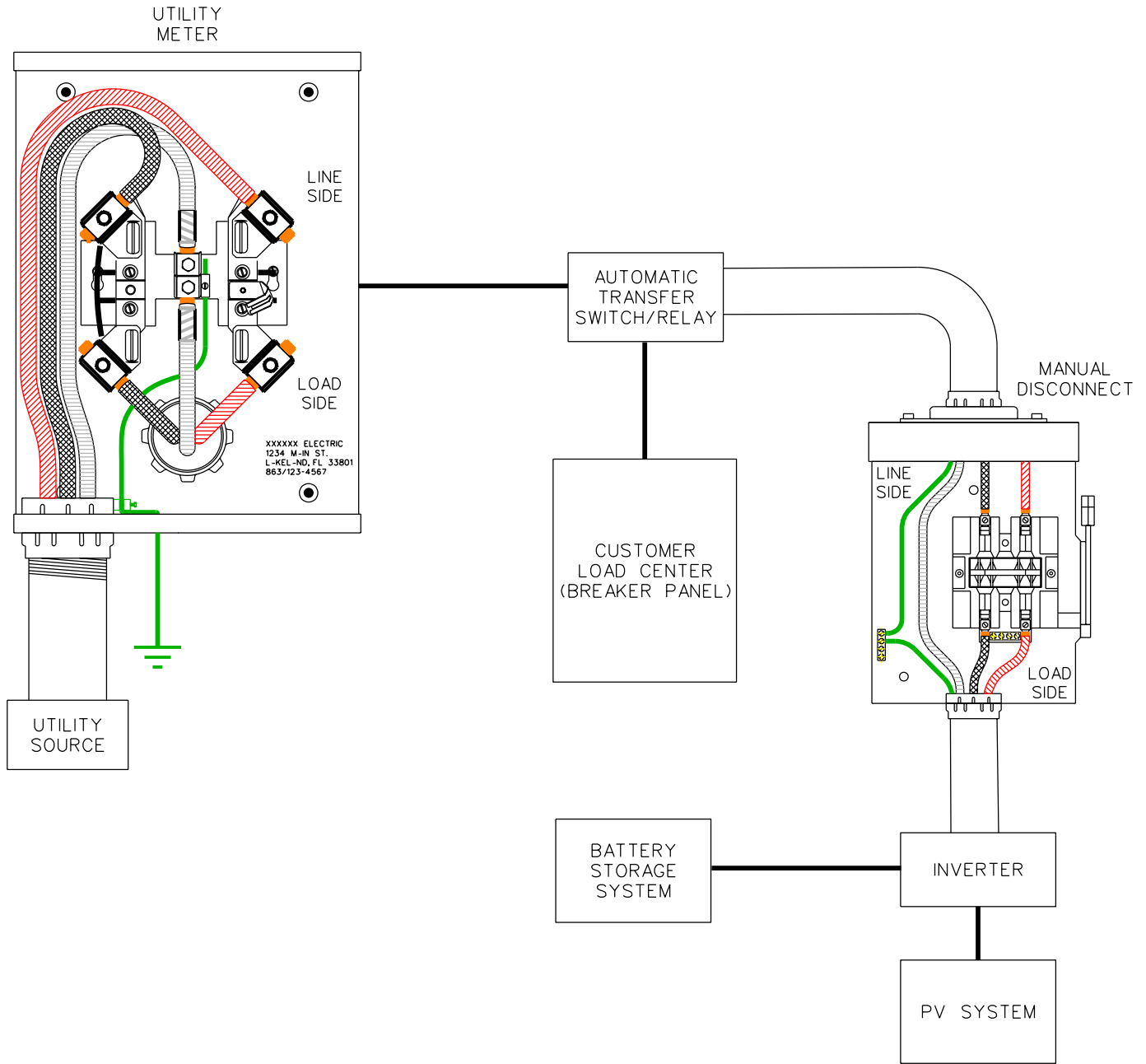

NOTES:

1. CUSTOMER CONNECTION FROM THE PV SYSTEM DISCONNECT SWITCH IS ON THE METER LINE SIDE LUG.
2. NEUTRAL CONNECTIONS ARE NOT MADE IN THE MANUAL DISCONNECT.
3. METER CANS AND DISCONNECT SWITCH BOXES SHALL BE PROPERLY GROUNDED.
4. WHILE ENTRY POINTS MAY DIFFER THAN SHOWN, TERMINATIONS SHALL BE MADE IN THE SPECIFIED LOCATIONS.
5. MANUAL DISCONNECT SWITCHES SHALL BE LOCATED ON THE EXTERIOR OF THE STRUCTURE.
6. SERVICE MUST UTILIZE PROPER CONDUIT, BUSHINGS, AND CONNECTORS.
7. THE UTILITY BILLING METER CAN SHALL NOT BE USED AS A PASSTHROUGH OR HAVE ANY ADDITIONAL CONNECTIONS MADE INSIDE IT.

JMF 10/25/19
 BRS 01/29/19
 XXX 99/99/99